

ITEM # _____

MODEL # _____

PROJECT NAME # _____

SIS # _____

AIA # _____

**LVA100B – 20 gal. Vegetable Washer & Dryer
Green Machine Series**



**LVA100B – 20 gal.
Vegetable Washer & Dryer
Green Machine Series**

660080 (LVA100B) LVA100B 20 gal. Veg. Washer & Dryer
115 V/1p/60Hz

Short Form Specification

Item No. _____

Unit to be Electrolux LVA100B – 20 gal. Vegetable Washer & Dryer. Electrical characteristics to be 115 V SINGLE-phase operation with Single speed at 400 rpm. Heavy duty Stainless steel body with an ergonomic design for easy use and cleanability. This Dito washing and drying machine presents all those characteristics of efficiency, functionality and hygiene that makes it an essential component on the modern kitchens. This appliance is designed for the efficient and safe treatment of vegetables in the commercial kitchen. It has been constructed on the basis of rigorous technical principles to guarantee functionality, long-term reliability and efficient running costs.

Main features

- Easy to Reach Control Panel.
- Easy Cleaning
- Easy to load Stainless Steel Inner Basket with Handle Grips
- Frame, external panel, lid and extractable basket all in 304 AISI Stainless steel and mounted on adjustable feet.
- Basket support in corrosion resistant aluminum.
- Lid Microswitch prevents the machine from starting when the lid is open.
- Electromagnetic device immediately stops the machine when the lid is opened during use.
- Very efficient and easy to clean filtering system.
- Internal chamber with rounded corners.
- Self-cleaning cycle of the internal washing chamber.
- This model has a cleansing container for liquid detergent and a sanitizing kit.
- Wash pump power: 3/4 HP
- Basket rotation motor power: 1/2 HP
- Power consumption: 900 watts
- Basket dimensions:
 - Diameter 19.5"
 - Height 10"
- Cycle load
 - light vegetables (leafy vegetables): 7 lbs.
 - heavy vegetables (large vegetables): 20 lbs.
- Rotation speed – 400 rpm
- Motor Power - 1-1/4 HP
- External Dimensions:
 - Height 39-3/8"
 - Depth 27-9/16"
 - Width 27-9/16"
- ETL electrical and sanitation listed.
- NEMA # : 5-15P
- Shipping weight – 220 lbs.
- Net Weight – 181 lbs.
- 2 year parts warranty, 1 year labor.

Optional Accessories

- Inner Basket (PNC 921014)



Approval: _____

Front View

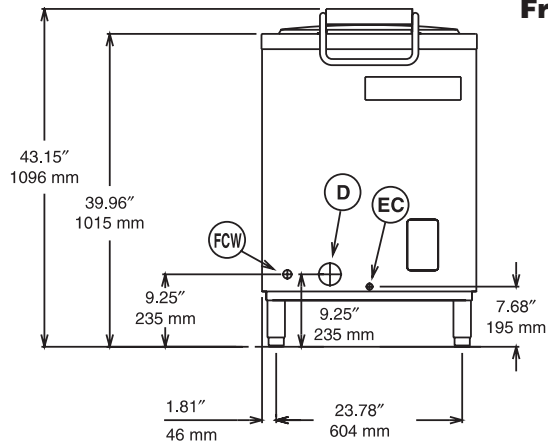

Top View

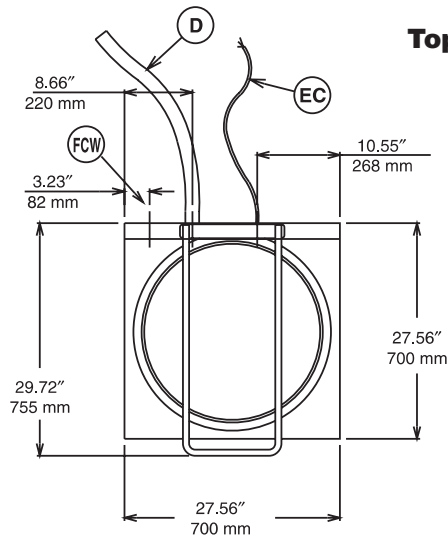

EC = Electrical connection
D = Water drain
FCW = Filtered Cold water

Side View

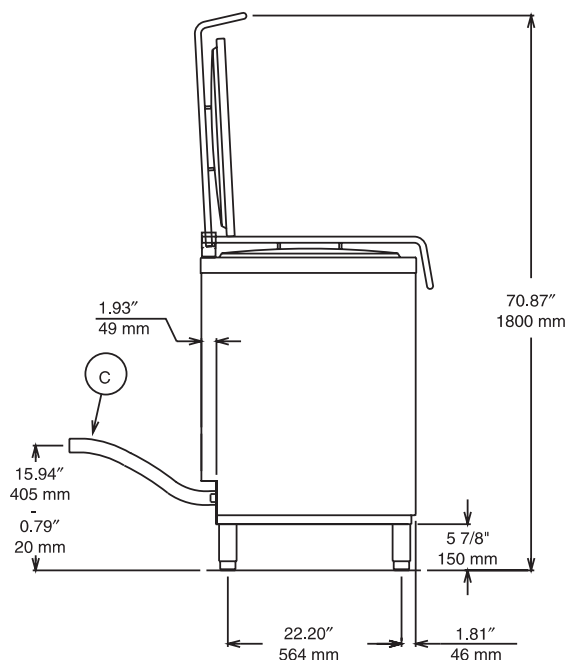

Electric

Supply voltage:

660080 (LVA100B)

115 V/1p/60Hz - 14A

Key Information

FUNCTION CONTROLS:

JET WASHING (Automatic cycle)

- water consumption 8 gal
- spray-washing in one direction for 30 seconds and for 30 seconds in opposite direction
- drain
- centrifugation drying for 30 seconds

"DIPPING" WASHING (Automatic cycle)

- water consumption 27 gal
- washing in one direction for 30 seconds and 30 seconds in opposite direction
- drain
- centrifugation drying for 30 seconds

"DIPPING WASHING with sanitizing product (Automatic cycle)

- water consumption 34,3 gal
- water top-up to level 2 with sanitizing product injection (0,0006 gal)
- washing in one direction for 30 seconds and for 30 seconds in opposite direction
- total water drain
- centrifugation drying for 20 seconds
- water re-fill to level 8 gal.
- spray washing in one direction for 30 seconds and for 30 seconds in opposite direction
- drain
- centrifugation drying for 30 seconds

MANUAL DISCHARGE

MANUAL CENTRIFUGATION

LVA100B – 20 gal. Vegetable Washer & Dryer
Green Machine Series

The company reserves the right to make modifications to the products without prior notice. All information correct at time of printing.

12-16-10