



EM Series 2 Drawer Refrigerated-Freezer Base 36"

ITEM # _____
 MODEL # _____
 PROJECT NAME # _____
 SIS # _____
 AIA# _____



EM Series

2 Drawer Refrigerated-Freezer Base 36"

727094 (COMP36)

2 Drawer Refrigerated-Freezer Base
36" (915 mm)

Short Form Specification

Item No. _____

Unit to be Electrolux Two (2) Drawer Refrigerated/Freezer Base with built-in compressor unit. Unit able to operate both as refrigerator or as freezer, with temperature range from -7.6 °F to +46.4 °F (-22 °C to +8 °C). Digital thermostat and display are protected by the stainless steel front panel. stainless steel front panel with incorporated stainless steel wire netting is easy to remove for access to the thermostat and to allow for easy cleaning. May be installed below any top unit. Perforated top surface provides the necessary ventilation to allow for a flush connection between base and Electrolux top units, eliminating the need for the top unit legs. Each drawer to accommodate one (1) 12" x 20" x 6" deep pan or one (1) 325 mm x 530 mm (1/1 GN) pan. Drawer guides with safety stop mechanism can support up to 264 lbs. (120 kg) and are removable for cleaning. Magnetic snap-in drawer gaskets are removable for cleaning. Perforated bottom plate in each drawer guarantees correct air-flow, allows for small pans to stand upright and is removable for cleaning. Perforated bottom plate can support up to 55 lbs. (25 kg). Forced air circulation for rapid cooling and an even temperature distribution. Access to all components from the front and bottom. CFC free (ecological refrigerant type: R404a, - gas in foam: cyclopentane). Suitable for use in ambient temperatures of up to 104 °F (40 °C). Rounded corners inside well for safe and easy cleaning. Constructed entirely in AISI 304 stainless steel with Scotch Brite finish. Right-angled side edges to allow flush fitting joints between units, minimizing gaps and possible dirt traps. Heavy duty stainless steel tubular drawer handles. Supplied with 6" (150 mm) height adjustable, removable legs. Unit may be installed on castors.



Main Features

- Two (2) Drawer Refrigerated/Freezer Base with built-in compressor unit.
- Unit able to operate both as refrigerator or as freezer, with temperature range from -7.6 °F to +46.4 °F (-22 °C to +8 °C).
- Digital thermostat and display are protected by the stainless steel front panel.
- Stainless steel front panel with incorporated stainless steel wire netting is easy to remove for access to the thermostat and to allow for easy cleaning.
- May be installed below any top unit.
- Perforated top surface provides the necessary ventilation to allow for a flush connection between base and Electrolux top units, eliminating the need for the top unit legs.
- Each drawer to accommodate one (1) 12" x 20" x 6" deep pan or one (1) 325 mm x 530 mm (1/1 GN) pan.
- Drawer guides with safety stop mechanism can support up to 264 lbs. (120 kg) and are removable for cleaning.
- Magnetic snap-in drawer gaskets are removable for cleaning.
- Perforated bottom plate in each drawer guarantees correct air-flow, allows for small pans to stand upright and is removable for cleaning.
- Perforated bottom plate can support up to 55 lbs. (25 kg).
- Forced air circulation for rapid cooling and an even temperature distribution.
- Access to all components from the front and bottom.
- CFC free (ecological refrigerant type: R404a, - gas in foam: cyclopentane).
- Suitable for use in ambient temperatures of up to 104 °F (40 °C).
- Rounded corners inside well for safe and easy cleaning.
- Constructed entirely in AISI 304 stainless steel with Scotch Brite finish.
- Right-angled side edges to allow flush fitting joints between units, minimizing gaps and possible dirt traps.
- Heavy duty stainless steel tubular drawer handles.
- Supplied with 6" (150 mm) height adjustable, removable legs.
- Unit may be installed on castors.

Optional Accessories

- KIT 4 SWIVELLING WHEELS - 2 WITH BRAKE PNC 880123

Approval: _____

Electrolux Professional, Inc.

www.electroluxusa.com/professional

10200 David Taylor Drive, Charlotte, NC 28262 • Telephone Number: 866-449-4200 • Fax Number: 704-547-7401



Electrolux

EM Series
2 Drawer Refrigerated-Freezer Base 36"

Front

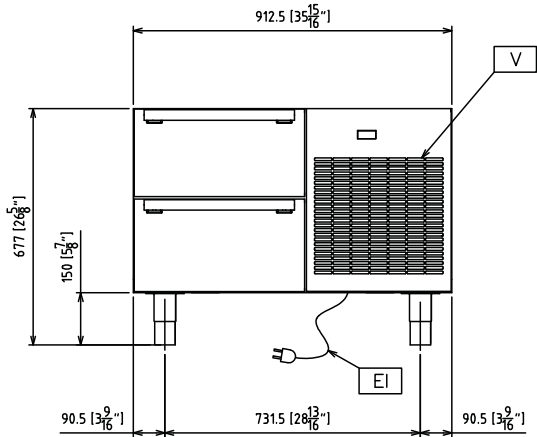

Top

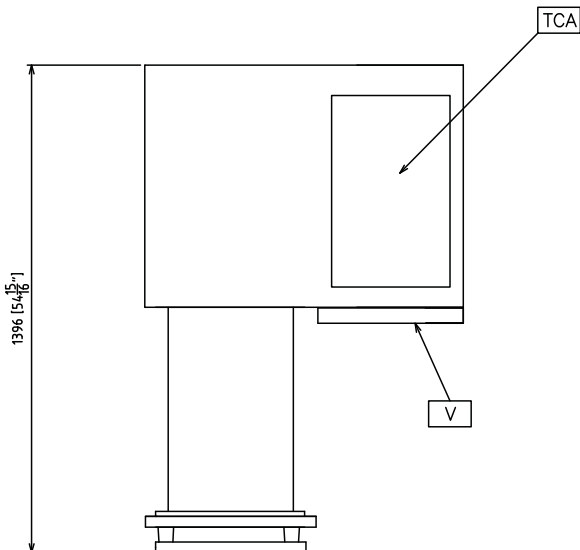

EI = Electrical connection
EQ = Equipotential screw

Side

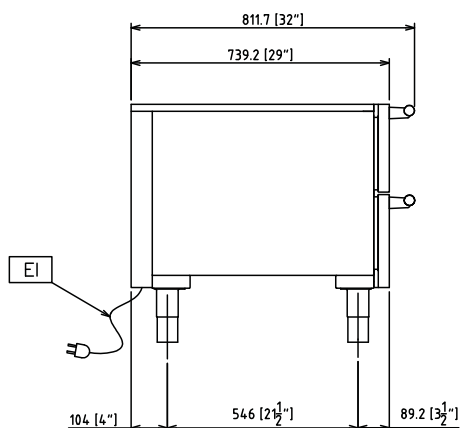

Electric

Supply voltage:	120 V/1N ph/60 Hz
Amps:	7
Total watts:	0.7 kW

Key Information

External dimensions, width	35 15/16" (913 mm)
External dimensions, depth	32 1/64" (813 mm)
External dimensions, height	26 3/4" (680 mm)
Net weight:	370 lbs (168 kg)
Shipping width:	33 7/16" (850 mm)
Shipping depth:	38 9/16" (980 mm)
Shipping height:	30 11/16" (780 mm)
Shipping weight:	430 lbs (195 kg)
Shipping volume:	22.94 ft ³ (0.65 m ³)
Refrigerant weight:	0.287 lbs (130 kg)

Refrigeration Data

Compressor power:	1/2 hp, self-contained
Refrigerant type:	R404a
Refrigeration power:	1958 W

EM Series
2 Drawer Refrigerated-Freezer Base 36"

The company reserves the right to make modifications to the products without prior notice. All information correct at time of printing.