

Item No.:	_____	Qty.	_____
Model No.:	_____		
Project No.:	_____		



12" Standard Series Sinks

12" Deep Standard Series One Compartment Stainless Steel Sinks

- 1C18X18-2-18X**
- 1C18X24-2-18X**
- 1C18X24-2-24X**
- 1C24X24-2-24X**

Options

- Faucets
- Tub Accessories
- Undershelves
- Rotary Drain Options
- H-Frame Stainless Steel Legs
- Stainless Steel Feet Options (bullet & flange styles)

Specifications

12" Standard Series Sink, with one compartment, both left and right drainboards, 10" backsplash, 16 gauge, 300 series stainless steel top and bowl, galvanized legs & adjustable feet, raised 1-1/2" rolled edge, includes 3-1/2" basket strainer, NSF approved

Features

- 16 Ga. stainless steel
- Welded construction for consistent metal gauge thickness throughout
- 12" (304.8 mm) deep tub with 3/4" (19.1 mm) coved radius tub corners
- All drainboards are die stamped for positive drainage
- 10" (254 mm) backsplash with tile ledge for easy installation
- Raised 1-1/2" (38.1 mm) diameter rolled edge
- 3-1/2" (88.9 mm) drain with basket strainer included
- 1-5/8" (41.3 mm) galvanized legs with 1" (25.4 mm) adjustable plastic feet

Materials

- Sink & Bowl: 16 Ga. 300 series stainless steel
- Top: Drainboards and backsplash are 16 gauge 300 series stainless steel.
- Legs: All sinks furnished with 1-5/8" (41.3 mm) diameter heavy gauge galvanized tubing with plated galvanized leg gussets and high impact corrosion resistant fully adjustable 1" (25.4 mm) feet.

Mechanical

- 1-1/8" (28.6mm) faucet holes on 8" (203.2mm) centers
- 3-1/2" (88.9mm) waste drain opening

Flyer Product

In keeping with our policy of continuing product improvement, Elkay SSP reserves the right to change product specifications without notice.



AUTOQUOTES



This specification describes an Elkay SSP product with design, quality and functional benefits to the user. When making a comparison of other producers' offerings, be certain these features are not overlooked.

Elkay SSP
 421 N. Freya St.
 Spokane, WA 99205
 Phone: 800-726-0553 Fax: 509-535-1493

Website: www.sspinc.net
 Email: sspsales@elkay.com
 ©2011 SSP INC.



Item No.: _____ Qty. _____

Model No.: _____

Project No.: _____

12" Standard Series Sinks

12" Deep Standard Series One Compartment Stainless Steel Sinks

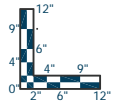
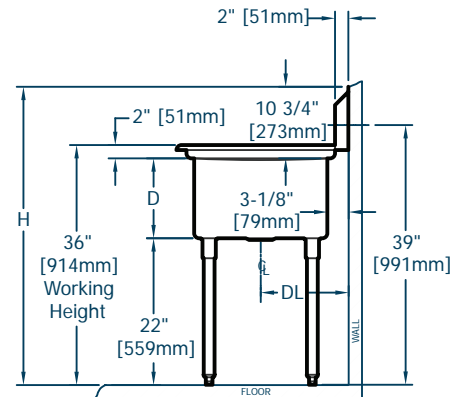
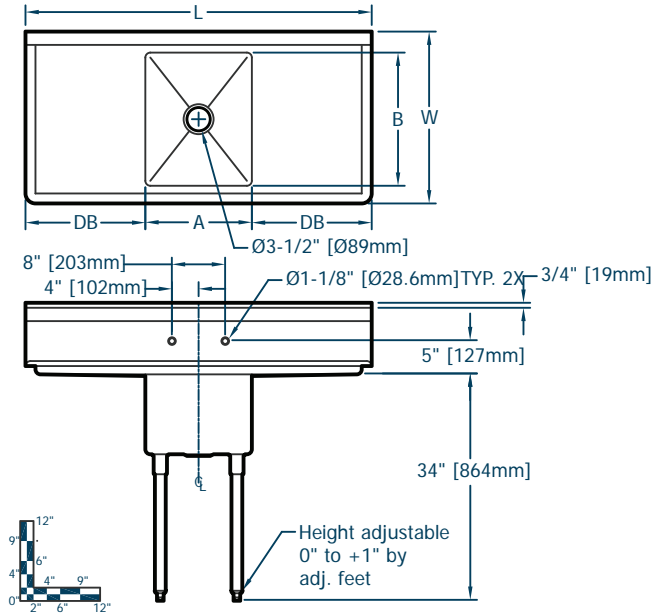

Height adjustable
0" to +1" by
adj. feet

12" Standard Series Sinks																			
Model Number	Bowl Dimensions						Overall Size			Drainboard		Drain	Weight						
	Width		Front-to-Back		Depth	Length L in. mm	Width		Height H in. mm	Location	Size		Location DL in. mm	lbs.	kg				
	A	mm	B	mm	D		mm	W			mm	DB				mm			
1C 18 X 18 2 18 X	18	457	18	457	12	305	54	1372	23.8	605	44.8	1137	L & R	18	457	12	305	126	57
1C 18 X 24 2 18 X	18	457	24	610	12	305	54	1372	29.8	757	44.8	1137	L & R	18	457	15	381	137	62
1C 18 X 24 2 24 X	18	457	24	610	12	305	66	1676	29.8	757	44.8	1137	L & R	24	610	15	381	153	69
1C 24 X 24 2 24 X	24	610	24	610	12	305	72	1829	29.8	757	44.8	1137	L & R	24	610	15	381	169	77

