

Item No.:	_____	Qty.:	_____
Model No.:	_____		
Project No.:	_____		

Economy Series Hand Sink

Economy 18" Hand Sink, Wall Mounted,, Towel & Soap Dispenser, Skirt, P-Trap



EHS-18TSX

Features

- 18 Gauge, 300 series stainless steel
- 6" Backsplash with 2" return
- Goose neck faucet
- Towel dispenser
- Soap dispenser
- 1-1/2" Drain opening
- Strainer, Skirt, and P-Trap included
- Z-clip mounting bracket
- Easy to clean and sanitize

Options

- Side Splashes
- Faucet Upgrade
- Apron Skirt
- Overflow

Materials

- Sink & Bowl: 18 gauge, 300 series stainless steel
- Top: Backsplash is 18 gauge, 300 series stainless steel

Mechanical

- 1-1/8" (29mm) faucet holes on 4" (102mm) centers
- 1-1/2" (38mm) waste drain opening

Flyer Product



AUTOQUOTES



In keeping with our policy of continuing product improvement, Elkay SSP reserves the right to change product specifications without notice.

This specification describes an Elkay SSP product with design, quality and functional benefits to the user. When making a comparison of other producers' offerings, be certain these features are not overlooked.

Elkay SSP
421 N. Freya St.
Spokane, WA 99205
Phone: 800-726-0553 Fax: 509-535-1493

Website: www.sspinc.net
Email: sspsales@elkay.com
©2011 Elkay

SNK-EHS18TSX10OCT2011

Page 1 of 2



Item No.: _____ Qty.: _____

Model No.: _____

Project No.: _____

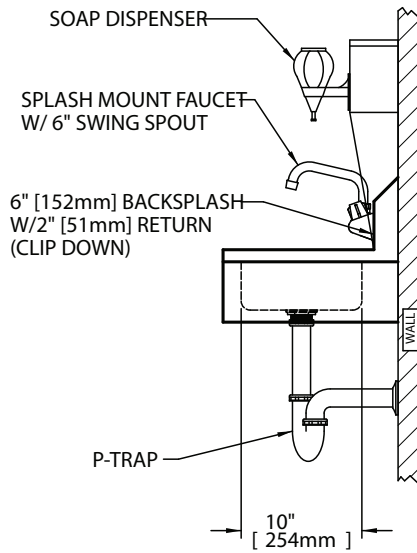
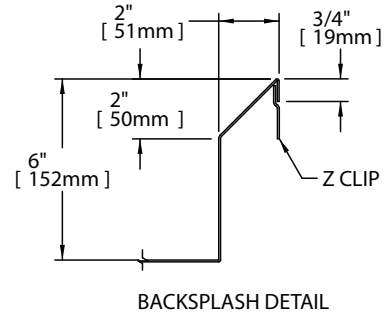
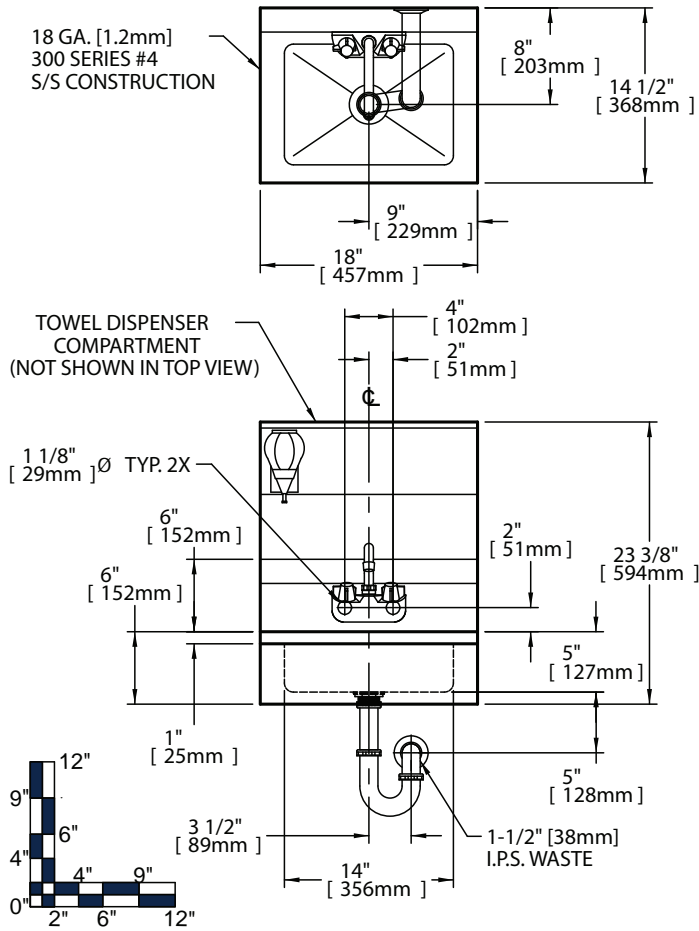

Economy Hand Sinks																
	Bowl Dimensions						Overall Size						Drain Location DL	Weight		
	Width		Front-to-Back		Depth		Width		Front-to-Back		Height			in.	kg	
	A	mm	B	mm	D	mm	L	mm	W	mm	H	mm				
EHS - 18 - TS X	10	254	14	356	5	127	14	356	18	457	11.0	279	10.0	254	21	10

* Custom sizes also available

