

Item No.:	_____	Qty.	_____
Model No.:	_____		
Project No.:	_____		



14" Spec-Line Series Sinks

14" Deep Spec-Line Series Two Compartment Stainless Steel Sinks

- | | |
|---|---|
| <input type="checkbox"/> SL2C16X20-R-18 | <input type="checkbox"/> SL2C20X28-R-20 |
| <input type="checkbox"/> SL2C18X18-R-18 | <input type="checkbox"/> SL2C20X28-R-24 |
| <input type="checkbox"/> SL2C18X18-R-24 | <input type="checkbox"/> SL2C24X24-R-24 |
| <input type="checkbox"/> SL2C18X24-R-18 | <input type="checkbox"/> SL2C24X24-R-30 |
| <input type="checkbox"/> SL2C18X24-R-24 | <input type="checkbox"/> SL2C24X30-R-24 |
| <input type="checkbox"/> SL2C18X30-R-18 | <input type="checkbox"/> SL2C24X30-R-30 |
| <input type="checkbox"/> SL2C18X30-R-24 | <input type="checkbox"/> SL2C30X30-R-24 |
| <input type="checkbox"/> SL2C20X20-R-20 | <input type="checkbox"/> SL2C30X30-R-30 |
| <input type="checkbox"/> SL2C20X20-R-24 | |

Options

- Overshelves & Pot Racks
- Skirts & End Splashes
- Faucets
- Additional Modified Faucet Holes
- Tub & Drainboard Modifications
- Tub Accessories
- Disposer Provisions
- Rotary Drain Options
- Undershelves
- Additional Front or Back Crossbracing
- Stainless Steel Flange Foot Option

Materials

- Sink & Bowl: 14 Ga. stainless steel
- Top: Drainboard and backsplash are 14 gauge stainless steel.
- Legs: All sinks furnished with 1-5/8" (41.3 mm) diameter heavy gauge stainless steel tubing with stainless steel leg gussets and high impact corrosion resistant fully adjustable 1" (25.4 mm) feet.

Mechanical

- 1-1/8" (38mm) faucet holes on 8" (203mm) centers
- 3-1/2" (89mm) waste drain opening



AUTOQUOTES



Specifications

14" Spec-Line Series Sink, with two compartments, right drainboard, 10" backsplash, 14 gauge, stainless steel top and bowl, stainless steel H-frame legs & adjustable feet, raised 1-1/2" rolled edge, includes 3-1/2" basket strainer, NSF approved

Features

- 14 Ga. stainless steel
- Welded construction for consistent metal gauge thickness throughout
- 14" (355.6 mm) deep tub with 3/4" (19.1 mm) coved radius tub corners
- Drainboard is die stamped for positive drainage
- 10" (254 mm) backsplash with tile ledge for easy installation
- Raised 1-1/2" (38.1 mm) diameter rolled edge
- 3-1/2" (88.9 mm) drain with basket strainers included
- 1-5/8" (41.3 mm) stainless steel H-Frame legs with 1" (25.4 mm) adjustable feet
- 2" (50.8 mm) divider between each tub

In keeping with our policy of continuing product improvement, Elkay SSP reserves the right to change product specifications without notice.

This specification describes an Elkay SSP product with design, quality and functional benefits to the user. When making a comparison of other producers' offerings, be certain these features are not overlooked.

Elkay SSP

421 N. Freya St.
Spokane, WA 99205
Phone: 800-726-0553 Fax: 509-535-1493

Website: www.sspinc.net
Email: sspsales@elkay.com
©2011 SSP INC.



Item No.: _____ Qty. _____

Model No.: _____

Project No.: _____

14" Spec-Line Series Sinks

14" Deep Spec-Line Series Two Compartment Stainless Steel Sinks

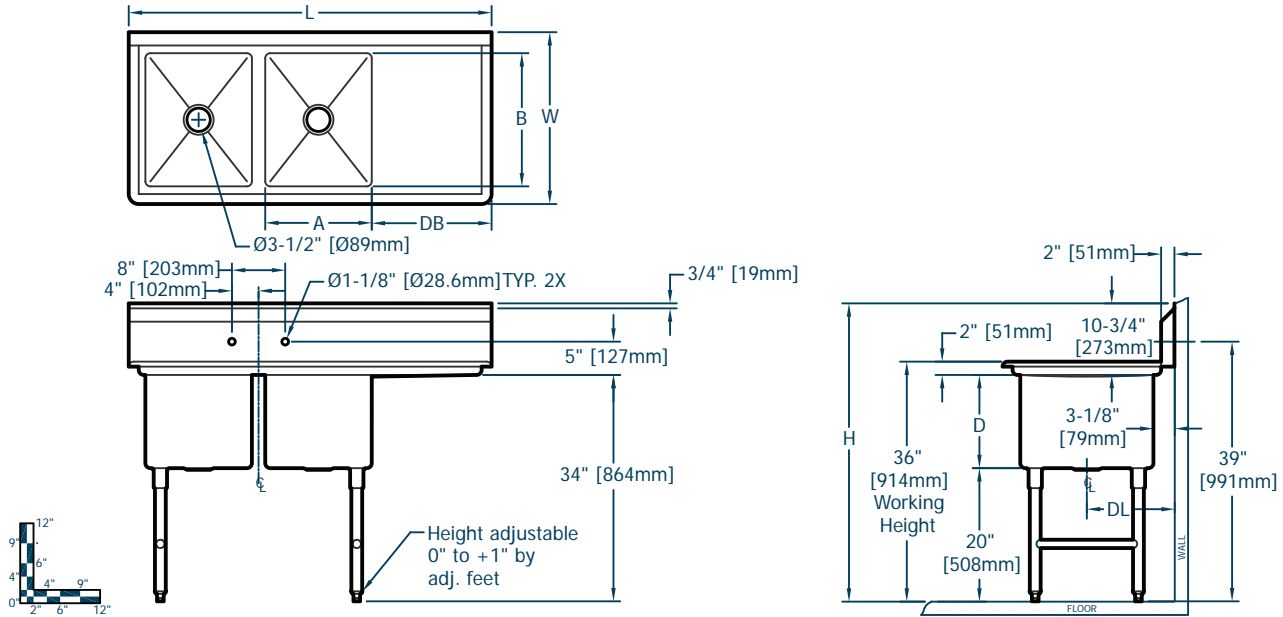

Spec-Line Series Sinks																			
Model Number	Bowl Dimensions						Overall Size			Drainboard		Drain		Weight					
	Width		Front-to-Back		Depth		Length		Width		Height		Location	Size DB	Location	lbs.	kg		
	A	mm	B	mm	D	mm	L	mm	W	mm	H	mm		in.	mm	DL	mm		
SL 2C 16 X 20 R 18	16	406	20	508	14	356	54.5	1384	25.8	656	44.8	1137	Right	18	457	13.1	333	175	79
SL 2C 18 X 18 R 18	18	457	18	457	14	356	58.5	1486	23.8	605	44.8	1137	Right	18	457	12.1	308	180	82
SL 2C 18 X 18 R 24	18	457	18	457	14	356	64.5	1638	23.8	605	44.8	1137	Right	24	610	12.1	308	189	86
SL 2C 18 X 24 R 18	18	457	24	610	14	356	58.5	1486	29.8	757	44.8	1137	Right	18	457	15.1	384	199	90
SL 2C 18 X 24 R 24	18	457	24	610	14	356	64.5	1638	29.8	757	44.8	1137	Right	24	610	15.1	384	209	95
SL 2C 18 X 30 R 18	18	457	30	762	14	356	58.5	1486	35.8	910	44.8	1137	Right	18	457	18.1	460	209	95
SL 2C 18 X 30 R 24	18	457	30	762	14	356	64.5	1638	35.8	910	44.8	1137	Right	24	610	18.1	460	219	99
SL 2C 20 X 20 R 20	20	508	20	508	14	356	64.5	1638	25.8	656	44.8	1137	Right	20	508	13.1	333	212	96
SL 2C 20 X 20 R 24	20	508	20	508	14	356	68.5	1740	25.8	656	44.8	1137	Right	24	610	13.1	333	218	99
SL 2C 20 X 28 R 20	20	508	28	711	14	356	64.5	1638	33.8	859	44.8	1137	Right	20	508	17.1	435	229	104
SL 2C 20 X 28 R 24	20	508	28	711	14	356	68.5	1740	33.8	859	44.8	1137	Right	24	610	17.1	435	238	108
SL 2C 24 X 24 R 24	24	610	24	610	14	356	76.5	1943	29.8	757	44.8	1137	Right	24	610	15.1	384	246	111
SL 2C 24 X 24 R 30	24	610	24	610	14	356	82.5	2096	29.8	757	44.8	1137	Right	30	762	15.1	384	268	122
SL 2C 24 X 30 R 24	24	610	30	762	14	356	76.5	1943	35.8	910	44.8	1137	Right	24	610	18.1	460	260	118
SL 2C 24 X 30 R 30	24	610	30	762	14	356	82.5	2096	35.8	910	44.8	1137	Right	30	762	18.1	460	293	133
SL 2C 30 X 30 R 24	30	762	30	762	14	356	88.5	2248	35.8	910	44.8	1137	Right	24	610	18.1	460	299	136
SL 2C 30 X 30 R 30	30	762	30	762	14	356	94.5	2400	35.8	910	44.8	1137	Right	30	762	18.1	460	334	151

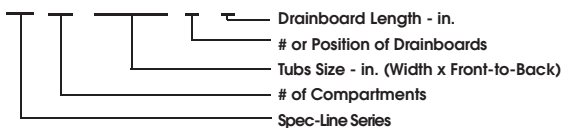

Elkay SSP
 421 N. Freya St.
 Spokane, WA 99205
 Phone: 800-726-0553 Fax: 509-535-1493

Website: www.sspinc.net
 Email: sspsales@elkay.com
 ©2011 SSP INC.