

# CONVO-HEAT DISPLAY CASE

## C O N C E P T

- Attractive hot food displays with curved front glass and stainless steel base
- Unique convection enhanced heat pattern
- Uniform distribution of heat and humidity throughout the case
- Thermostatically controlled up to 195° F
- Available in two sizes
- Overhead LED light for better visibility
- Convenient rear sliding service doors
- Removable intermediate wire shelf
- Options: lighted front menu panel



**HOT 300 Shown:**  
with standard stainless  
steel front panel

### HOT 200



208/240V

*Shown with lighted menu panel*

### HOT 300

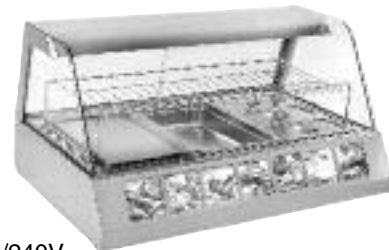

208/240V

*Shown with lighted menu panel*

## SPECIFICATIONS

MODEL	ELECTRICAL	EXTERIOR DIMENSIONS	CAPACITY	SHIP WEIGHT	NEMA PLUG
HOT 200	208/240V, 2000W, 7/9 Amps	32"Wx29"Dx23"H (add 4" for legs)	(2)12"x20"x2 1/2"pans plus wire shelf	260 lbs	6-15 P
HOT 300	208/240V, 2000W, 7/9 Amps	45"Wx29"Dx23"H (add 4" for legs)	(3)12"x20"x2 1/2"pans plus wire shelf	270 lbs	6-15 P

#### OPTIONAL ACCESSORIES:

- Lighted menu panel for **HOT 200**
- Lighted menu panel for **HOT 300**

**WARRANTY: Limited one year parts and labor**



765 WESTMINSTER STREET PROVIDENCE, RI 02903  
TEL: (401)273-3300 FAX: (401)273-3328 E-mail:sales@equipex.com  
www.equipex.com



# TURBO DISPLAY CASE

## CONCEPT

### REVELATION



VHC 1000

VHF 1000

### HEATED OR COLD DISPLAY CASE COUNTERTOP WITH CURVED FRONT

*Combines uniform air pattern with enhanced product visibility*

- Stainless steel base construction
- Overhead LED light for better visibility
- Curved front lift up see-through plexiglass door
- Rear lift up plexiglass serving door
- Modular design with detachable heater or compressor unit
- Unique convection enhanced air pattern
- Thermostatically controlled up to 200°F or down to 40°F
- Stainless steel slotted upper shelf
- Bottom removable tray for easy cleaning

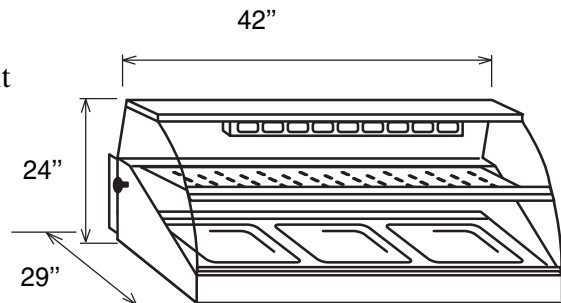

## SPECIFICATIONS

MODEL	ELECTRICAL	EXTERIOR DIMENSIONS	DISPLAY SURFACE DIMENSIONS PAN CAPACITY	SHIP WEIGHT	NEMA PLUG
VHC 1000	120V, 1800W, 15 Amps  208/240V, 2000W, 7/9 Amps	42"Wx29"Dx24"H (add 4" for legs)	Upper Shelf: 36"Wx12"D (3) 12"x10"x2 1/2"pans Bottom Shelf: 36"Wx21"D (3) 12"x20"x4"pans	220 lbs	5-15 P (U.S.) 5-20 P (Can)  6-15 P
VHF-1000	120V, 500W, 15 Amps (2) 1/4 horse power compressors		290 lbs	5-15 P	

**WARRANTY: Limited one year parts and labor**



765 WESTMINSTER STREET PROVIDENCE, RI 02903  
 TEL: (401)273-3300 FAX: (401)273-3328 E-mail:sales@equipex.com  
 www.equipex.com