

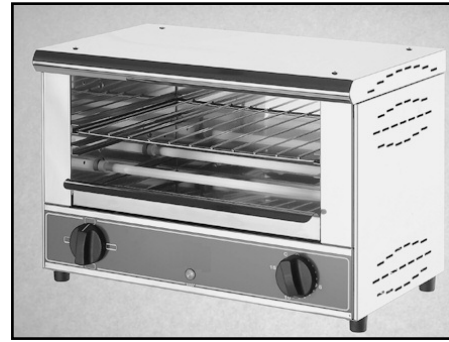

TOASTER OVEN

CONCEPT

- Ideal for melting, warming and toasting
- One or two shelf snack toasters feature top and bottom infra-red heat
- 15-minute timer for controlled operation with a continuous mode
- Compact footprint
- Stainless steel exterior and interior construction
- One or two wire racks and crumb tray included
- Open-style models furnished with heat-resistant removable rack handles



BAR-100 120 or 208/240 V



BAR-200 120 or 208/240 V



RST-127 208/240 V



BAR-106/1 120 V



RST-227 208/240 V



BAR-206/1 120 V



765 WESTMINSTER STREET PROVIDENCE, RI 02903
 TEL: (401)273-3300 FAX: (401)273-3328 E-mail: sales@equipex.com
 www.equipex.com



TOASTER OVENS

**BAR-100
BAR-106**

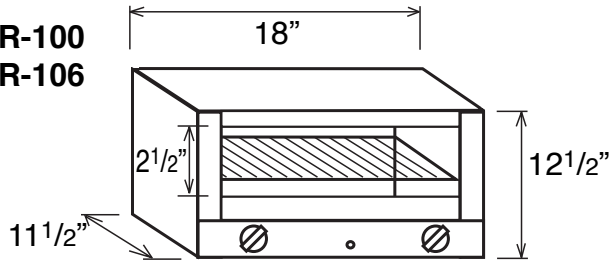

RST-127

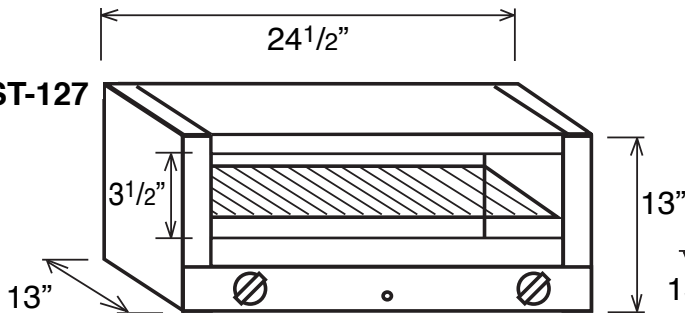

**BAR-200
BAR-206**

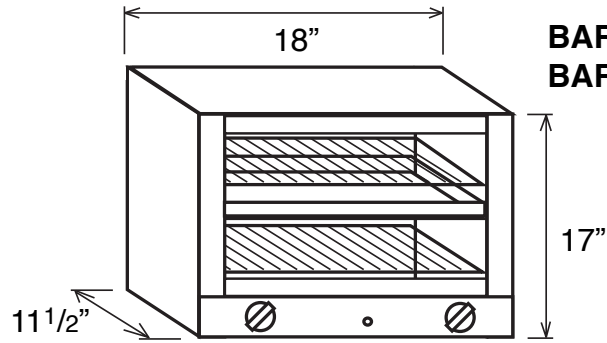

RST-227

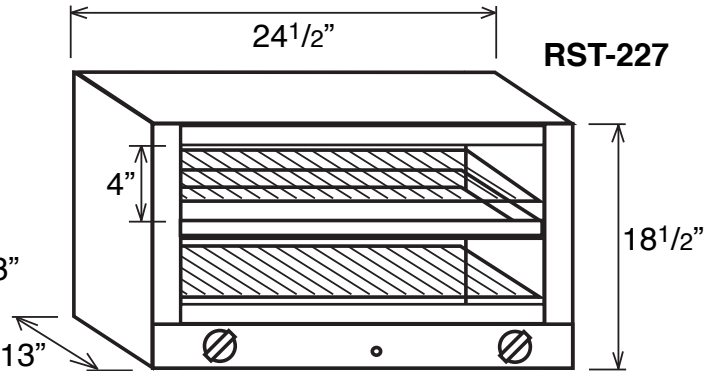

SPECIFICATIONS INSTALLATION CLEARANCE: 2" EACH SIDE, TOP AND BACK

MODEL	ELECTRICAL	DIMENSIONS	WORK SURFACE	SHIPPING WEIGHT	NEMA PLUG
BAR 100/1	120V, 1PH 1.7KW, 14 Amps	18"Wx11 1/2"Dx12 1/2"H	13 3/4"x9 3/4"	24 lbs	5-15 P
BAR 100	208/240V, 1PH 2KW, 7/9 Amps	18"Wx11 1/2"Dx12 1/2"H	13 3/4"x9 3/4"	24 lbs	6-15 P
BAR 200/1	120V, 1PH 1.7KW, 14 Amps	18"Wx11 1/2"Dx17"H	(2) 13 3/4"x9 3/4"	28 lbs	5-15 P
BAR 200	208/240V, 1PH 3KW, 11/13 Amps	18"Wx11 1/2"Dx17"H	(2) 13 3/4"x9 3/4"	28 lbs	6-15 P
BAR 106/1	120V, 1PH 1.1KW; 10 Amps	18"Wx11 1/2"Dx12 1/2"H plus 4" for handle	13 3/4"x9 3/4"	25 lbs	5-15P
BAR 206/1	120V, 1PH 1.65KW, 14Amps	18"Wx11 1/2"Dx17"H plus 4" for handle	(2) 13 3/4"x9 3/4"	30 lbs	5-15P
RST-127	208/240V, 1PH, 3.5KW, 12/15 Amps	24 1/2"Wx13"Dx13"H	18 1/2"x11"	40 lbs	6-20P
RST-227	208/240V, 1PH, 5.2KW, 19/22 Amps	24 1/2"Wx13"Dx18 1/2"H	(2) 18 1/2"x11"	50 lbs	L6-30P

WARRANTY: Limited one year parts and labor



765 WESTMINSTER STREET PROVIDENCE, RI 02903
 TEL: (401)273-3300 FAX: (401)273-3328 E-mail: sales@equipex.com
 www.equipex.com