



TURBOHEAT DISPLAY CASE

CONCEPT

HEATED DISPLAY CASE COUNTERTOP WITH CURVED FRONT

*Combines uniform heat pattern with
enhanced product visibility*

- Stainless steel base construction
- Overhead fluorescent light for better visibility
- Curved front lift up glass door
- Rear lift up serving door
- Modular design with detachable heater unit
- Unique convection enhanced heat pattern
- Thermostatically controlled up to 200° F
- Stainless steel slotted upper shelf
- Bottom removable tray for easy cleaning

REVELATION



VHC 1000

120 V

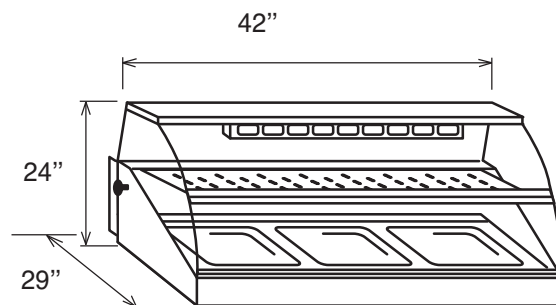

SPECIFICATIONS

MODEL	ELECTRICAL	EXTERIOR DIMENSIONS	DISPLAY SURFACE DIMENSIONS PAN CAPACITY	SHIP WEIGHT	NEMA PLUG
VHC 1000	120V, 1800W, 15 Amps	42"Wx29"Dx24"H (add 4" for legs)	Upper Shelf: 36"Wx12"D (3) 12"x10"x2 1/2"pans Bottom Shelf: 36"Wx21"D (3) 12"x20"x4"pans	130 lbs	5-15 P (U.S.) 5-20 P (Can)

WARRANTY: Limited one year parts and labor



765 WESTMINSTER STREET PROVIDENCE, RI 02903
TEL: (401)273-3300 FAX: (401)273-3328 E-mail:sales@equipex.com
www.equipex.com