



EV9100-01

A-10 10" Clear Housing

Clear filter housing



A-10 10" Clear Housing: EV9100-01

BENEFITS

- 10" utility housing
- Holds any 10" drop-in filter or softening cartridge
- Clear bowl with mounting bracket
- Versatile basic design accommodates many applications

INSTALLATION TIPS

- Install vertically so bowls hang down.
- Allow 2-1/2" clearance below the cartridge for easy cartridge replacement
- Make sure o-ring on bowl is sufficiently lubricated
- Always screw on bowls by hand; Do not use a housing wrench.

OPERATION TIPS

- Change cartridges on a regular 6 month preventative maintenance program
- Change cartridges according to cartridge specifications

APPLICATION/SIZING

- For foodservice applications
- Utility housing holds most 10" drop in cartridges

A-10 10" Clear Housing

SPECIFICATIONS

Overall Dimensions: 12-1/2"H x 4-7/8"W x 4-7/8"D

Inlet connection: 1/2" FNPT

Outlet connection: 1/2" FNPT

Service Flow Rate: Maximum 5 gpm (19 Lpm)

Pressure Requirements: 10 psi -125 psi
(0.7 – 8.6 bar), non-shock

Temperature: 35°F - 100°F (2-38°C)

No electrical connection required

Shipping Weight: 4 lbs.

Operating Weight: 5 lbs.

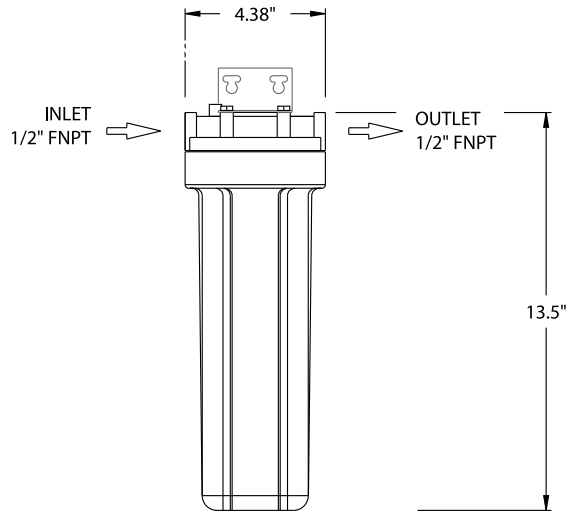

WARRANTY

Everpure water treatment systems (excluding replaceable elements) are covered by a limited warranty against defects in material and workmanship for a period of five years after date of purchase. Everpure replaceable elements (filter cartridges and water treatment cartridges) are covered by a limited warranty against defects in material and workmanship for a period of one year after date of purchase. See printed warranty for details. Everpure will provide a copy of the warranty upon request.

EVERPURE®

Worldwide Headquarters:
EVERPURE, LLC
1040 Muirfield Drive
Hanover Park, Illinois 60133
Toll Free (800) 323-7873
Tel (630) 307-3000
Fax (630) 307-3030
<http://www.everpure.com>

In Europe:
Pentair Water Belgium B.V./B.A.
Industriepark Wolfstee
Toekomstlaan 30
B- 2200 Herentals
BELGIUM
TEL: +32.(0).14.283.500
FAX: +32.(0).14.283.505

In Japan:
Hashimoto MN Bldg. 7F
3-25-1 Hashimoto Sagamihara-Shi
Kanagawa 229-1103
JAPAN
TEL: 81.(0)42.775.3011
FAX: 81.(0)42.775.3015

Everpure
1040 Muirfield Drive
Hanover Park, IL 60133