



DEV9100-22

CGS-22 20" Dual Series Housing

Foodservice System Housing for Drop-In Cartridges



CGS-22 20" Dual Series Housing: DEV9100-22

BENEFITS

- 20" low profile Slim Line dual bowl housing in Series configuration
- Manufactured of durable polypropylene and has excellent chemical resistance
- System includes water pressure gauge
- Equipped with a pressure relief button to relieve water pressure during cartridge changes
- Includes wall mounting bracket and hardware for fast and easy installation
- System is shipped fully assembled
- Choose the appropriate cartridges for your needs
- Cartridges sold separately

INSTALLATION TIPS

- Choose a mounting location suitable to support the full weight of the system when operating
- Install vertically so bowls hang down
- Allow 2-1/2" clearance below the cartridge for easy cartridge replacement
- Make sure O-ring on bowl is sufficiently lubricated
- Always screw on bowls by hand; do not use a housing wrench
- Flush filter by running water through filter according to cartridge instructions

OPERATION TIPS

- Change cartridges on a regular 6 month preventative maintenance program
- Change cartridges when capacity is reached or when pressure decreases
- Always inspect O-ring; change and/or lubricate if necessary
- Clean bowl with mild solution of detergent before inserting new cartridge
- Always flush the filter cartridge at time of installation and cartridge change

APPLICATION/SIZING

- For foodservice applications
- Bowl housing assembly accepts drop in cartridges
- Capacity: varies according to filter cartridge used

CGS-22 20" Dual Series Housing

SPECIFICATIONS

Overall Dimensions:
25"H x 14.25"W x 5.25"D

Inlet connection: 1/2"

Outlet connection: 1/2"

Service Flow Rate:
Maximum 4.0 gpm (15.1 Lpm)

Pressure Requirements:
30 - 125 psi (2.1 - 8.6 bar), non-shock

Temperature: 40 - 100°F (4.4 - 38°C)

No electrical connection required

The contaminants or other substances removed by this drinking water system are not necessarily in your water. Do not use with water that is microbiologically unsafe or of unknown quality without adequate disinfection before or after the system.

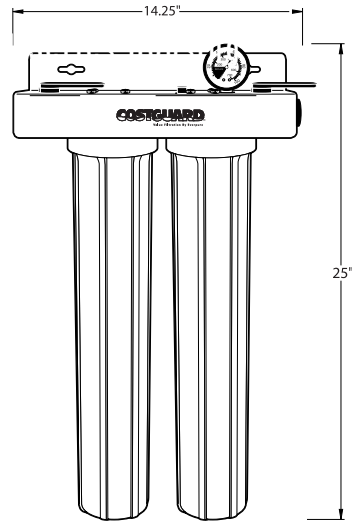

WARRANTY

Everpure water treatment systems (excluding replaceable elements) are covered by a limited warranty against defects in material and workmanship for a period of five years after date of purchase. Everpure replaceable elements (filter cartridges and water treatment cartridges) are covered by a limited warranty against defects in material and workmanship for a period of one year after date of purchase. See printed warranty for details. Everpure will provide a copy of the warranty upon request.

EVERPURE®

Worldwide Headquarters:
EVERPURE, LLC
1040 Muirfield Drive
Hanover Park, Illinois 60133
Toll Free (800) 323-7873
Tel (630) 307-3000
Fax (630) 307-3030
<http://www.everpure.com>

In Europe:
Pentair Water Belgium B.V./B.A.
Industriepark Wolfstee
Toekomstlaan 30
B- 2200 Herentals
BELGIUM
TEL: +32.(0).14.283.500
FAX: +32.(0).14.283.505

In Japan:
Hashimoto MN Bldg. 7F
3-25-1 Hashimoto Sagamihara-Shi
Kanagawa 229-1103
JAPAN
TEL: 81.(0)42.775.3011
FAX: 81.(0)42.775.3015