



EV9797-92
MRS-20T

Complete Mineral Reduction Water Processing System



MRS-20T System: EV9797-92
4CB5 cartridge: EV9617-17
MR-20 Cartridge: EV9273-69

BENEFITS

Improves equipment life and performance by removing at least 90%+ of all dissolved solids that cause scale build-up

Especially useful on low capacity steamers, warmers, small steam boilers and other evaporative equipment that are not emptied each day

Heating surfaces maintain peak heat transfer efficiency, reducing cycle times and energy consumption

Protects against taste and odor causing contaminants while removing dirt, particulates and dissolved minerals

Less frequent deliming of equipment means reduced maintenance and service costs

Sanitary cartridge replacement is simple, quick and clean. Internal filter parts are never exposed to handling or contamination

Two-part design makes installation flexible, and small footprint easily fits in any kitchen

INSTALLATION TIPS

Choose a mounting location suitable to support the full weight of the system when operating

Mount system convenient to the post water softener supply line and for routing the outlet and drain lines

The tank assembly may be mounted above, below or alongside (preferred) of the water processor assembly

Install vertically with cartridges hanging down. Allow 2-1/2" clearance below the cartridge for easy cartridge replacement

The water inlet must supply a minimum of 0.5 gpm at 50-85 psi on a consistent basis

Deliming of equipment prior to application is recommended

OPERATION TIPS

Replace the 4CB5 carbon filter every 12 months.

Change the MR-20 mineral reduction cartridge every two years, or as needed.

Cartridge replacement schedules assume the system is installed on softened water.

Outlet Water Production: 21 gal per day (79.5 Liters per day) @ 60 psig (420 kPa), 77° F (25° C). Water production depends on supply water pressure and temperature.

Wastewater Production:
74 gal. per day (280l) @ 60 psig (414 kPa), 77° F (25° C).

Wastewater drain line capacity: 3 gpm (11.4 lpm) to open atmosphere

Storage Tank Capacity:
3 gallon tank; effective/usable capacity: 2.5 gal. (9.5l)

APPLICATION/SIZING

Mineral Reduction System for foodservice applications

Ideal for:
Flash steamers, conventional steamers, cheese melters, combi-ovens and coffee/espresso machines

Uniquely designed for low volume applications (approximately 21 gpd nominal consumption)

System includes mineral reduction processor, carbon filter cartridge, reverse osmosis cartridge, storage tank and pressure regulator assembly

MRS-20T

SPECIFICATIONS

Overall Dimensions:

Processor - 25"H x 22.5"W x 5"D

Tank - 27"H x 22.5"W x 11.25"D

Inlet and Outlet connection:

3/8" OD John Guest tubing fitting (provided)

3/8" ID beverage hose

Wastewater line and Sample port connection:

1/4" OD John Guest tubing fitting (provided)

Pressure Requirements:

10 psi-125 psi (69-862 kPa), non-shock

Water Supply:

0.5 gpm (1.9l) @ 50-85 psi (345-586 kPa)

Inlet Temperature: 40-100°F (4-38°C)

Inlet TDS: 1,500 ppm max recommended

Operating Weight: 50 lbs.

The contaminants or other substances removed or reduced by this drinking water system are not necessarily in your water. Do not use with water that is microbiologically unsafe or of unknown quality without adequate disinfection before or after the system. Systems certified for cyst reduction may be used with disinfected water that may contain filterable cysts.

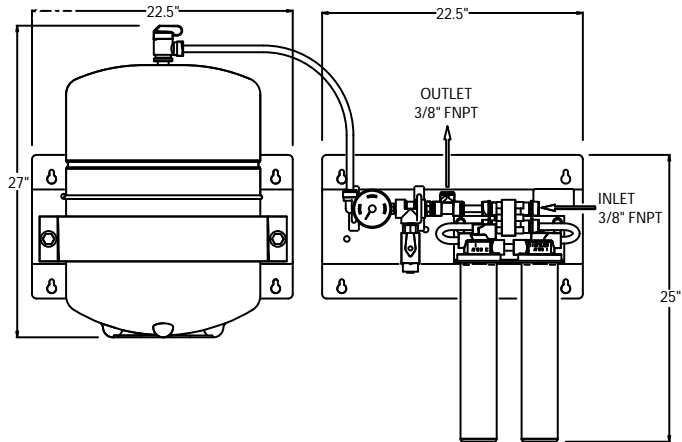

WARRANTY

Everpure water treatment systems (excluding replaceable elements) are covered by a limited warranty against defects in material and workmanship for a period of five years after date of purchase. Everpure replaceable elements (filter cartridges and water treatment cartridges) are covered by a limited warranty against defects in material and workmanship for a period of one year after date of purchase. See printed warranty for details. Everpure will provide a copy of the warranty upon request.

EVERPURE®

Worldwide Headquarters:

EVERPURE, LLC
1040 Muirfield Drive
Hanover Park, Illinois 60133
Toll Free (800) 323-7873
Tel (630) 307-3000
Fax (630) 307-3030
<http://www.everpure.com>

In Europe:

Pentair Water Belgium B.V./B.A.
Industriepark Wolfstee
Toekomstlaan 30
B- 2200 Herentals
BELGIUM
TEL: +32.(0).14.283.500
FAX: +32.(0).14.283.505

In Japan:

Hashimoto MN Bldg. 7F
3-25-1 Hashimoto Sagamihara-Shi
Kanagawa 229-1103
JAPAN
TEL: 81.(0)42.775.3011
FAX: 81.(0)42.775.3015

Everpure
1040 Muirfield Drive
Hanover Park, IL 60133