



MRS-350/350CC

MRS Reverse Osmosis System

Configurable system that delivers reverse osmosis water for multiple foodservice applications



MRS-350 System:
 EV9970-17 (115VAC/60Hz)
 EV9970-31 (230VAC/50Hz)
 EV9970-32 (240VAC/50Hz)

MRS-350CC System:
 EV9970-18 (115VAC/60Hz)
 EV9970-33 (230VAC/50Hz)
 EV9970-34 (240VAC/50Hz)

Pre-Filter Kit: EV9795-81

7TO-BW Cartridge: EV9607-04

MR-350 Cartridge: EV9627-07

7CO-BW Cartridge: EV9627-05

P5 Cartridge: EV9109-08

- System shown with optional Pre-filter kit.

BENEFITS

Improves equipment life and performance by removing at least 90%+ of all dissolved solids that cause scale build-up

Guards against taste and odor causing contaminants while removing dirt, particulates and dissolved minerals that can adversely affect taste of water and beverages

Sanitary cartridge replacement is simple, quick and clean - internal filter parts are never exposed to handling or contamination

Wall mount design allows flexible installation

Reduces limescale build-up that can cause excessive machine downtime and increased maintenance costs — plus, scale reduction reduces energy costs

“CC” models introduce a small amount of hardness minerals back into the treated water. This controlled re-mineralization is desirable for coffee and other applications that require some hardness to achieve optimum results

INSTALLATION TIPS

Choose a mounting location capable of safely supporting the full weight of the system when in operation

Delimiting of existing water using equipment is recommended

Never use saddle valve for connection

Use 3/8" (9.5 mm) minimum water line

The water inlet must supply a minimum of 1.0 gpm (3.8 lpm)

Install vertically with cartridges hanging down and allow 3" (76 mm) on all four sides of unit for cover removal and service access

The product water tubing/piping and associated fittings connecting the RO product outlet to the equipment being serviced should be suitable for use with high purity water

Refer to Installation, Operation & Maintenance Manual for cartridge flushing and RO start-up

OPERATION TIPS

Change filter cartridges on a regular 6-month preventative maintenance program

Change RO cartridges on a regular 2-year preventative maintenance program

Change cartridges when capacity is reached

Always flush the filter cartridge at time of installation and cartridge change

Proper pre-treatment is required to control RO Cartridge (membrane) scale formation and/or fouling

- Raw water hardness in excess of 7 grains per gallon (120 ppm) should be softened

- The raw water may contain particulates and the use of a pre-filter is recommended

Contact EVERPURE Technical Service for pre-treatment recommendations

APPLICATION / SIZING

Mineral Reduction System for foodservice applications

Ideal for: Flash steamers, conventional steamers, cheese melters, combi-ovens and coffee/espresso machines

Daily Production Rate:
 350 gallons per day (1,325 lpd) nominal
 0.243 gpm (0.92 lpm) nominal

For use in coffee, steam, reconstitution, ice and multiple applications

MRS Reverse Osmosis System

SPECIFICATIONS

Overall Dimensions:

38" H x 15" W (20.5" W with Prefilter) x 8" D
 965 mm H x 381 mm W
 (521 mm W with Prefilter) x 203 mm D
 [Add 3" (76 mm) on all 4 sides for cover removal and service access]

Available Voltages and Power Cord Plug Types:

115VAC/60Hz - NEMA 5-15P
 230VAC/50Hz - CEE 7/7 "Schuko"
 240VAC/50Hz - AS 3112

Inlet and outlet connection:

3/8" (9.5 mm) OD tube connection

Wastewater line connection:

1/4" (6.4 mm) OD tube connection

Daily Production Rate:

350 gpd (1,325 lpd) nominal
 0.243 gpm (0.92 lpm) nominal

Service Flow Rate:

Dependant on water pressure in storage tank and line size(s) to equipment

Pressure Requirements:

Operating:
 25 - 80 psi (1.72-5.52 bar), non-shock
 Maximum Static:
 100 psi (6.89 bar), non-shock

Minimum Water Supply: 1.0 gpm (3.8 lpm)

Inlet Temperature: 40–100°F (4–38°C)

Inlet TDS: 1,500 ppm max recommended

Operating Weight: 35 lbs. (15.9 kg.) (not including storage tanks)

The contaminants or other substances removed or reduced by this system are not necessarily in your water. Do not use with water that is microbiologically unsafe or of unknown quality without adequate disinfection before or after the system.

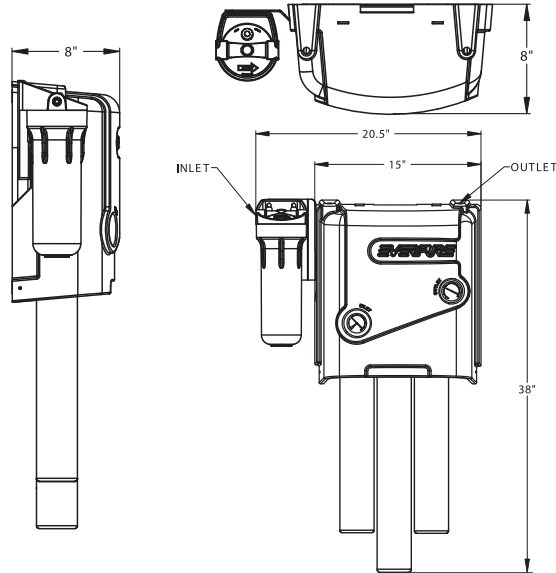

Power Cord Plug Types

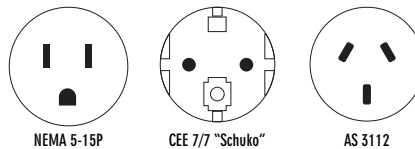

WARRANTY

MRS-350/350CC system (excluding replaceable elements) is covered by a limited warranty against defects in material and workmanship for a period of one year after the date of purchase.

Everpure replaceable elements (filter cartridges and water treatment cartridges) are covered by a limited warranty against defects in material and workmanship for a period of one year after date of purchase. See printed warranty for details. Everpure will provide a copy of the warranty upon request.



Everpure offers a full line of water storage tanks. See "ROmate Storage Tanks" specification sheet or contact your Everpure sales representative for more information.



EVERPURE, LLC
 1040 Muirfield Drive
 Hanover Park, Illinois 60133
 Toll Free (800) 323-7873
 Tel (630) 307-3000
 Fax (630) 307-3030
<http://www.everpure.com>

In Europe:
 N.V. EVERPURE (EUROPE) S.A.
 INDUSTRIEPARK WOLFSTEE
 TOEKOMSTLAAN 30
 B-2200 HERENTALS
 BELGIUM
 TEL 32 -14-283500
 FAX 32-14-283505

In Japan:
 EVERPURE JAPAN LLC
 HASHIMOTO MN BLDG. 7F
 3-25-1 HASHIMOTO SAGAMIHARA-SHI
 KANAGAWA 229-1103
 JAPAN
 TEL 81-(0)42-775-3011
 FAX 81-(0)42-775-3015