

GLASS DOOR MERCHANDISER REFRIGERATORS

Sliding Doors



EVEREST
REFRIGERATION

www.EVERESTref.com

EM – Series

• EMGR33(B) • EMGR48(B) • EMGR69(B)



EMGR33



EMGR33B



EMGR48



EMGR48B



EMGR69



EMGR69B

Cabinet Construction

Heavy duty white coated steel for cabinet interior and exterior. High quality stainless steel interior floor with round edges for convenient cleaning. White coated aluminum drain pan. 2.5" thick high density foamed-in-place polyurethane insulation. Adjustable screw legs for leveling. One additional heavy duty adjustable screw leg located at bottom of front cabinet for weight support for model EMGR69.

Refrigeration System

- Bottom mounted condensing unit
- Removable bottom grill and slide-out condensing unit for easy repair and maintenance
- Oversized condenser and evaporator coils quickly achieve and maintain desired temperature
- Forced-air cooling with oversized evaporator fan motors providing balanced airflow throughout cabinet to ensure faster temperature drop
- Environmentally friendly CFC free R-134A refrigerant
- Air defrost controlled by thermostat
- Copper tube and aluminum fin evaporator with anti-corrosive coating
- Energy efficient condensate drain pan with wicking pads
- Pre-wired and ready to plug, 115V/60Hz/1Ph, NEMA 5-15P

Doors

- Black PVC door frames
- Low emissivity double pane glass system reflects UV rays and improves insulation for maximized energy efficiency
- Automatic self-close by weight
- Removable doors and stainless steel door tracks for easy cleaning

Lighting

- Shielded vertical LED interior lighting with on/off switch for energy saving, less heat generation and enhanced illumination (available from 2015 models)

Shelving

- Four epoxy coated wire shelves per section
- Stainless steel pilasters and shelf clips

Temperature Control

- Factory preset temperature, 35°F
- Temperature setting range from 32°F to 42°F
- Easy to set thermostat dial

Options

- 2 1/2" and 4" diameter casters (3 1/2" and 5" overall height)

GLASS DOOR MERCHANDISER REFRIGERATORS (SLIDING DOORS)

• Project / Customer _____

• Item No. _____

• Model No. _____

Warranty

 **5 Year — Compressor Warranty**
3 Year — Parts & Labor Warranty
Applicable to units purchased after July 1, 2014.

Contact

 201 W. Artesia Blvd, Compton, CA 90220
T. (310) 323-6586, (800) 444-6285
F. (310) 323-7524, (310) 761-1127

GLASS DOOR MERCHANDISER REFRIGERATORS

Sliding Doors



EM – Series • EMGR33(B) • EMGR48(B) • EMGR69(B)

EVEREST
www.EVERESTref.com

Dimensions

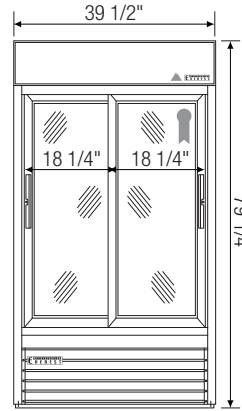
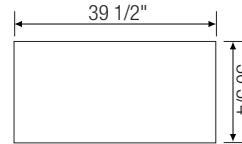
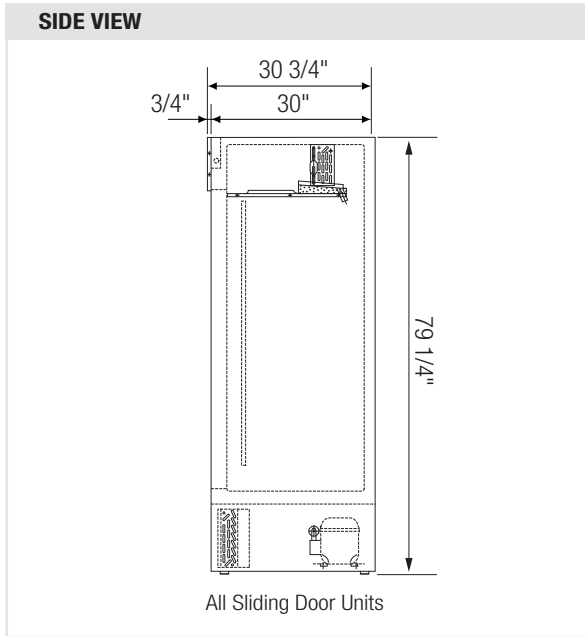

▲ EMGR33(B)

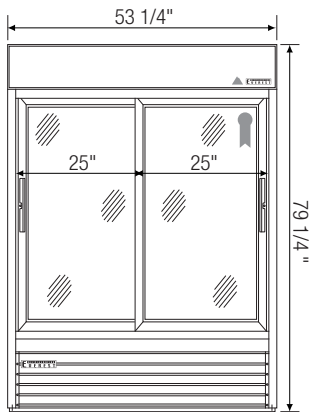
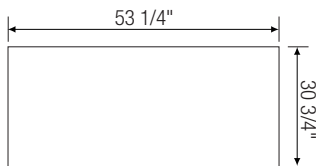

▲ EMGR48(B)

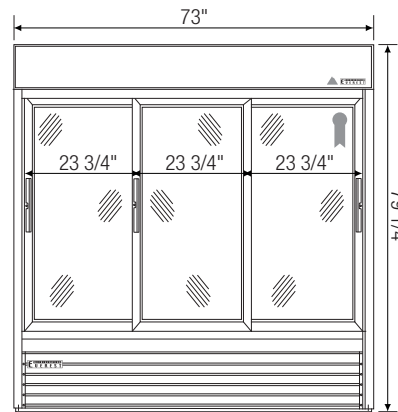
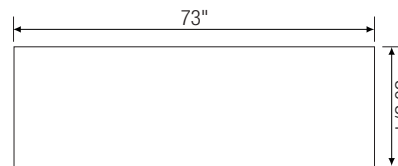

▲ EMGR69(B)

Model	Ref/ Frz/ Dual	# of Doors	Capacity (Cu.Ft.)	HP	Refrigerant	# of Shelves	Capacity 20 oz. Bottles	Power (V-Hz-Ph)	Amps	Crated Weight (LBS)	Exterior Dimensions (Inches)			Ref = Refrigerator Frz = Freezer Dual = Ref & Frz Combo
											L	D	H	
EMGR33(B)	Ref	2(Sliding)	33	1/3	R-134A	8	336	115-60-1	4.16	410	39 1/2	30 3/4	79 1/4	
EMGR48(B)	Ref	2(Sliding)	48	1/2+	R-134A	8	448	115-60-1	9.00	520	53 1/4	30 3/4	79 1/4	
EMGR69(B)	Ref	3(Sliding)	69	3/4+	R-134A	12	672	115-60-1	11.00	668	73	30 3/4	79 1/4	

Disclaimer: Product dimensions are for general purposes and not absolute value. Slight variations may exist. If dimensions are critical, please contact Everest.