



BACK MOUNT UNDERCOUNTER FREEZERS

Back Mounted Condensing Unit

ETB – Series

• ETBF1 • ETBSF2 • ETBF2 • ETBWF2 • ETBF3

Cabinet Construction

Heavy duty stainless steel interior and exterior, and galvanized steel finished bottom and back wall of exterior. High quality 16 gauge stainless steel worktop, ABS evaporator drain cover. 2.5" thick high density foamed-in-place polyurethane insulation. Four 4" diameter casters (front casters with brakes). Door heater installation around inside cabinet frame to prevent moisture build-up.

Refrigeration System

- Back mounted condensing unit
- Oversized condenser and evaporator coil cools to set and maintain temperature in minimum time period
- Forced-air cooling with oversized evaporator fan motors providing balanced airflow throughout cabinet to ensure faster temperature drop
- Slide-out condensing unit for convenient repair and maintenance
- Front air breathing for built-in applications
- Environmentally friendly CFC free R-134A and R-404A refrigerant
- 350 watt defrost heater controlled by electrical timer
- Copper tube and aluminum fin evaporator with anti-corrosive coating
- Energy efficient condensate drain pan assembly heated by high side copper tube
- Pressure relief port located at housing interior for rapid re-entry
- Pre-wired and ready to plug, 115V/60Hz/1Ph, NEMA 5-15P

Doors

- Heavy duty stainless steel interior and exterior
- 2.5" thick foamed-in-place polyurethane insulation
- Rounded corners for a sleek and modern appearance
- Heavy duty adjustable torsion spring self-closing door system
- One piece snap-in magnetic door gasket for easy replacement
- Heavy duty recessed door handles for a flat surface
- All 2014 models come standard with door locks.

Shelving

- Two epoxy coated wire shelves per section
- Stainless steel pilasters and shelf clips

Temperature Control

- Factory preset temperature, -4°F
- Temperature setting range from -10°F to 32°F
- Easy to set analog thermostat

Option

- 4" high stainless steel backsplash for worktop use



ETBF1

ETBSF2



ETBF2



ETBWF2



ETBF3

• Project / Customer _____
 • Item No. _____
 • Model No. _____

Warranty

5 Year — Compressor Warranty
 3 Year — Parts & Labor Warranty
 Applicable to units purchased after July 1, 2014



Please visit our website for updated Energy Efficiency information

201 W. Artesia Blvd, Compton, CA 90220
 T. (310) 323-6586, (800) 444-6285 F. (310) 323-7524
www.EVERESTref.com

BACK MOUNT UNDERCOUNTER FREEZERS

Back Mounted Condensing Unit



EVEREST REFRIGERATION

ETB – Series

• ETBF1 • ETBSF2 • ETBF2 • ETBWF2 • ETBF3

Dimensions

SIDE VIEW

Optional

4" high backsplash

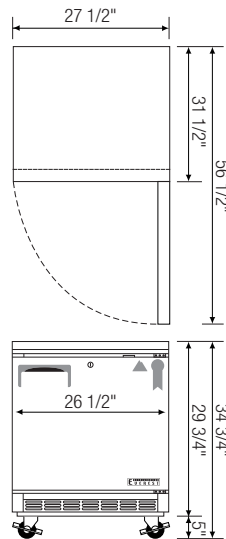
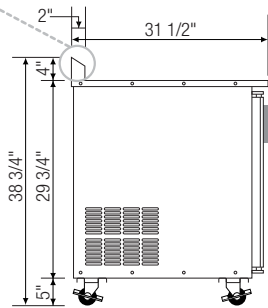

▲ ETBF1

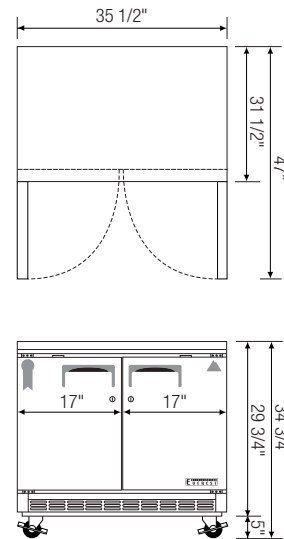

▲ ETBSF2

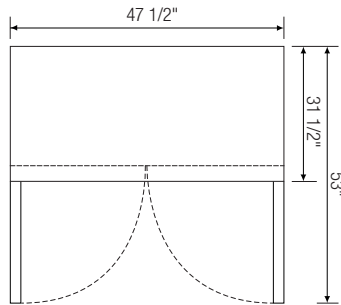
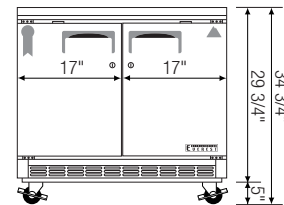
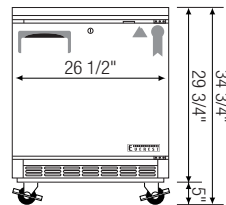

▲ ETBF2

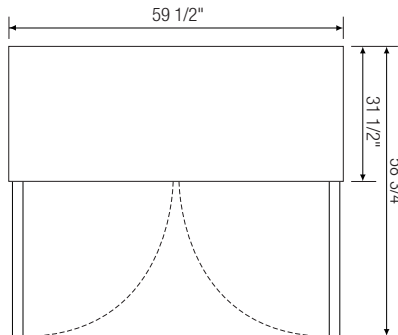

▲ ETBWF2

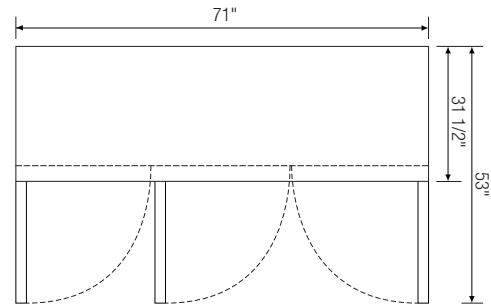

▲ ETBF3

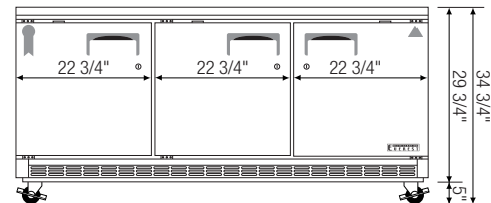
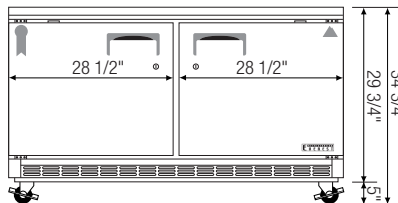
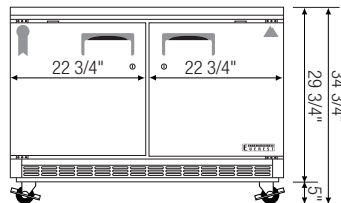

Model	Ref/ Fzr/ Dual	# of Doors	Capacity (Cu.Ft.)	HP	Refrigerant	# of Shelves	Power (V-Hz-Ph)	Amps	Crated Weight (LBS)	Exterior Dimensions (Inches)			* Height does not included 5" for caster. Ref = Refrigerator Fzr = Freezer Dual = Ref & Fzr Combo
										L	D	H *	
ETBF1	Fzr	1	5.6	1/3+	R-134A	2	115-60-1	5.20	192	27 1/2	31 1/2	29 3/4	
ETBSF2	Fzr	2	7.5	1/3+	R-134A	4	115-60-1	6.40	224	35 1/2	31 1/2	29 3/4	
ETBF2	Fzr	2	10.3	1/3+	R-134A	4	115-60-1	6.40	278	47 1/2	31 1/2	29 3/4	
ETBWF2	Fzr	2	15	1/2	R-404A	4	115-60-1	7.50	304	59 1/2	31 1/2	29 3/4	
ETBF3	Fzr	3	18.3	1/2	R-404A	6	115-60-1	7.67	397	71	31 1/2	29 3/4	

Disclaimer: Product dimensions are for general purposes and not absolute value. Slight variations may exist. If dimensions are critical, please contact Everest.

Specifications subject to change without notice.

www.EVERESTref.com

201 W. Artesia Blvd, Compton, CA 90220
T. (310) 323-6586, (800) 444-6285 F. (310) 323-7524