



SIDE MOUNT UNDERCOUNTER DUAL TEMPS

Side Mounted Condensing Unit

ET – Series

• ETRF2 • ETRF3

Cabinet Construction

Heavy duty stainless steel interior and exterior, and galvanized steel finished bottom and back wall of exterior. High quality 16 gauge stainless steel worktop, ABS evaporator drain cover. 2.5" thick high density foamed-in-place polyurethane insulation. Four 4" diameter casters (front casters with brakes). Door heater installation around inside cabinet frame to prevent moisture build-up.

Refrigeration System

- Side mounted condensing unit for extra interior space compared to back mounted units
- Oversized condenser and evaporator coil cools to set and maintain temperature in minimum time period
- Forced-air cooling with oversized evaporator fan motors providing balanced airflow throughout cabinet to ensure faster temperature drop
- Removable side panel and slide-out condensing unit for convenient repair and maintenance
- Removable condenser coil air filter for easy cleaning
- Environmentally friendly CFC free and R-404A refrigerant
- Air defrost, temperature initiated and terminated for refrigerator compartment, and adjustable, time initiated 350 watt defrost heater, both time and temperature terminated for fail-safe backup for freezer compartment
- Copper tube and aluminum fin evaporator with anti-corrosive coating
- Energy efficient condensate drain pan assembly heated by high side copper tube
- Pressure relief port located at housing interior for rapid re-entry
- Pre-wired and ready to plug, 115V/60Hz/1Ph, NEMA 5-15P

Doors

- Heavy duty stainless steel interior and exterior
- 2.5" thick high density foamed-in-place polyurethane insulation
- Rounded corners for a sleek and modern appearance
- Heavy duty adjustable torsion spring self-closing door system
- One piece snap-in magnetic door gasket for easy replacement
- Heavy duty recessed door handles for a flat surface

Lighting

- Safety shielded incandescent interior lighting

Shelving

- Two epoxy coated wire shelves per section
- Stainless steel pilasters and shelf clips

Temperature Control

- Factory preset temperature, 35°F for refrigerators and -4°F for freezers
- Temperature setting range from 33°F to 41°F for refrigerators and -10°F to 32°F for freezers
- Easy to read digital temperature display
- Easy to program push button temperature control
- Microchip digital monitoring system with a variety of functions to monitor and maintain optimum temperature



ETRF2

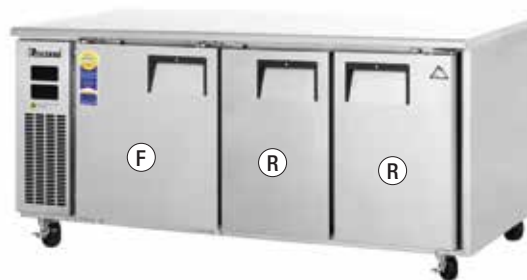

ETRF3

Option

- 4" high stainless steel backsplash for worktop use

• **Project / Customer** _____

• **Item No.** _____

• **Model No.** _____

Warranty

5 Year — Compressor Warranty
3 Year — Parts & Labor Warranty
 Applicable to units purchased after July 1, 2014



Please visit our website for updated Energy Efficiency information

201 W. Artesia Blvd, Compton, CA 90220
 T. (310) 323-6586, (800) 444-6285 F. (310) 323-7524
www.EVERESTref.com

SIDE MOUNT UNDERCOUNTER DUAL TEMPS

Side Mounted Condensing Unit



ET – Series

• ETRF2 • ETRF3

Dimensions

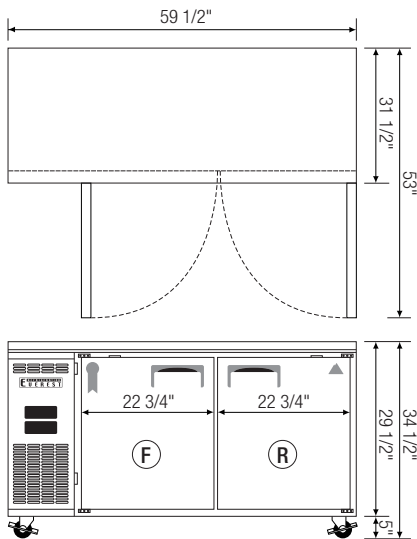
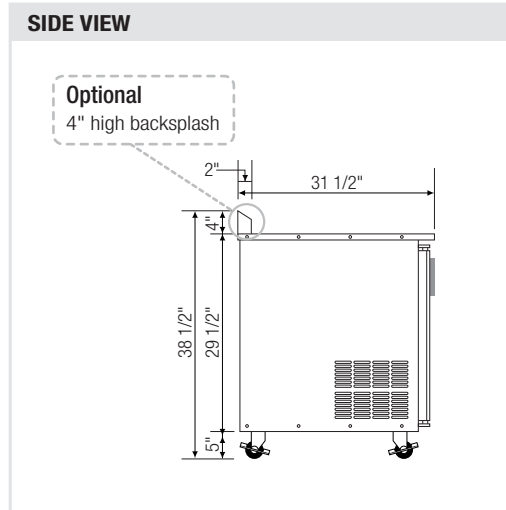

▲ ETRF2

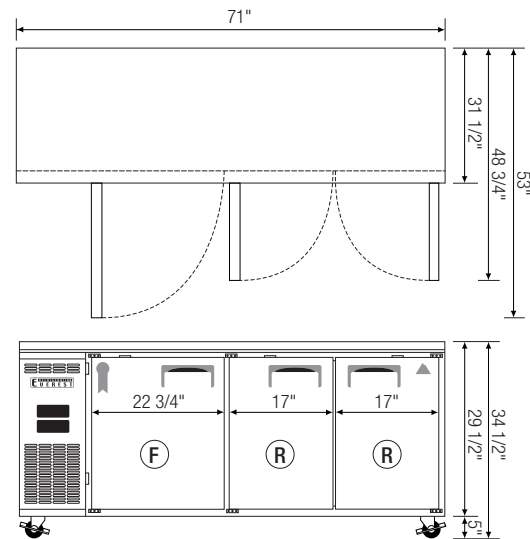

▲ ETRF3

Model	Ref/ Fzr/ Dual	# of Doors	Capacity (Cu.Ft.)	HP	Refrigerant	# of Shelves	Power (V-Hz-Ph)	Amps	Crated Weight (LBS)	Exterior Dimensions (Inches)			* Height does not included 5" for caster. Ref = Refrigerator Fzr = Freezer Dual = Ref & Fzr Combo
										L	D	H *	
ETRF2	Dual	2	9(Ref) 9(Fzr)	1/2	R-404A	4	115-60-1	7.54	324	59 1/2	31 1/2	29 1/2	
ETRF3	Dual	3	14(Ref) 8(Fzr)	1/2	R-404A	6	115-60-1	7.77	364	71	31 1/2	29 1/2	

Disclaimer: Product dimensions are for general purposes and not absolute value. Slight variations may exist. If dimensions are critical, please contact Everest.

Specifications subject to change without notice.

www.EVERESTref.com

201 W. Artesia Blvd, Compton, CA 90220
T. (310) 323-6586, (800) 444-6285 F. (310) 323-7524