

Deep Undercounter Tables

SUR/SWR Series

- SUR-46 • SWR-46
- SUR-67 • SWR-67



Item # _____

Standard Features

- Our deep undercounter units are designed with durability and strength that you will not find in any other products in its class.
- All stainless steel interior and exterior construction for a clean & safe food environment. Coved corner floor to meet NSF requirements.
- Heavy duty stainless steel door with full length recessed door handles; interior in-step design for added insulation and protection of door gasket.
- Factory balanced refrigeration system, environmentally friendly R-134A Refrigerators.
- Refrigerators maintain product temperatures from 33° to 38°F.
- Side breathing refrigeration system for built-in applications.
- Standard with rail system which holds (2) shelves per door and rails that can also accommodate (2) 12" x 20" foodservice pans (pans sold separately).



SWR-46



SUR-67

Options & Accessories

- 6" adjustable legs (set of 4)
- 2-1/2 casters (set of 4, front 2 w/ clips)
- Additional epoxy coated shelves (supports included)
- Universal tray slides
- Stainless steel back panel
- 220 volts / 50 cycles / 1 phase



	Model	Door	Capacity (cu. ft.)	Shelves	Amps	HP	Voltage	Nema Plug	Cord Length	Cabinet Dimension			Shipping (Wt. / Cubes)	
										L	D*	H**		
Undercounter	SUR-46	1	9.9	2	5.4	1/4	115/60/1	5-15P	8'	46" (1169 mm)	32-1/4" (819.15 mm)	31" (787 mm)	318 (144 kg)	43 (1.217 m ³)
	SUR-67	2	18.6	2	6.5	1/3	115/60/1	5-15P	8'	67-1/4" (1708.15 mm)	32-1/4" (819.15 mm)	31" (787 mm)	490 (222 kg)	62 (1.755 m ³)
	SWR-46	1	9.9	4	5.4	1/4	115/60/1	5-15P	8'	46" (1169 mm)	32-1/4" (819.15 mm)	34" (787 mm)	318 (144 kg)	43 (1.217 m ³)
	SWR-67	2	18.6	4	6.5	1/3	115/60/1	5-15P	8'	67-1/4" (1708.15 mm)	32-1/4" (819.15 mm)	34" (787 mm)	490 (222 kg)	62 (1.755 m ³)

* Depth does not include 1" bumper.
** Height does not include 5" casters (6" overall) or 6" optional legs.

Specifications Undercounter / Undercounter

Construction

Heavy duty stainless steel exterior top, front and sides. Galvanized back panel. Interior completely constructed of heavy duty stainless steel with coved corner floor. Door is heavy duty stainless steel exterior and high impact ABS plastic interior, in-step design with stainless steel hinged solid doors and positive seal. Provided with magnetic door gaskets, removable without tools, self-closing and with 120° stay open feature. Recessed full length door handle.

Door openings have a plastic breaker strips to retard condensate formation. Unit comes complete with a 2" CFC-Free polyurethane insulation, foamed in place.

Refrigeration system

Self-contained capillary tube system using environmentally friendly (CFC Free) R-134a refrigerant. Side mounted compressor on right side for built-in applications. Evaporator coil is mounted to interior top panel encased in stainless steel. Large fan motor and fan blades for better air flow.

Tables are designed to maintain temperatures between 33° F to 38° F in the interior cabinet.

Shelving

(2) Epoxy coated shelving per door with channel slides for supports. Adjustable in 2" increments per shelf.

Others

Unit is supplied standard with a 8' cord and plug (Nema 5-15p). Standard with 5" diameter casters, front two with brakes.

Warranty

(24) month labor and parts warranty. 5 year compressor warranty (Continental U.S.A. & Canada only).

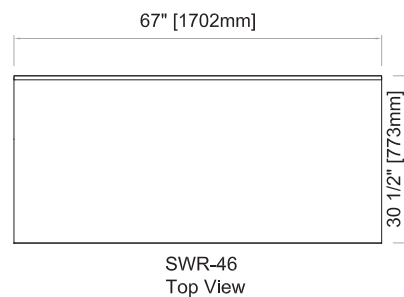
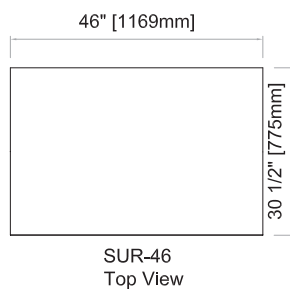
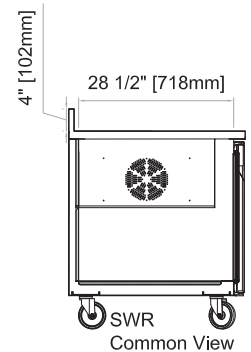
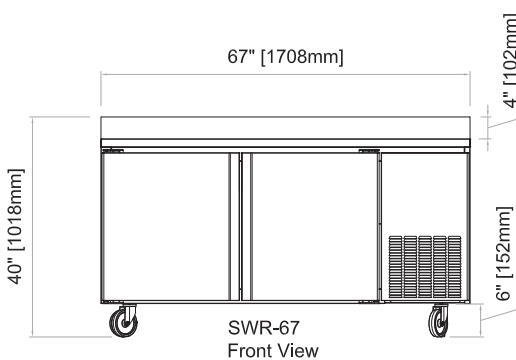
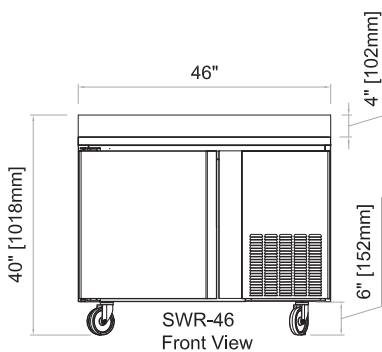
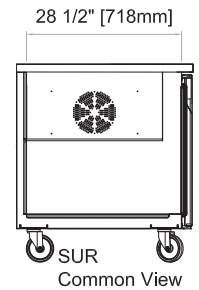
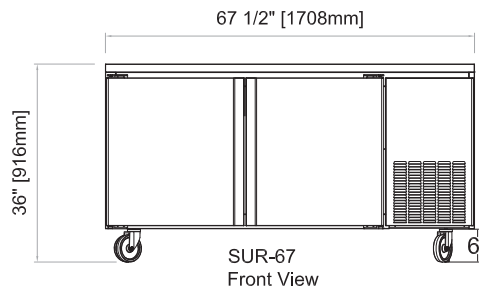
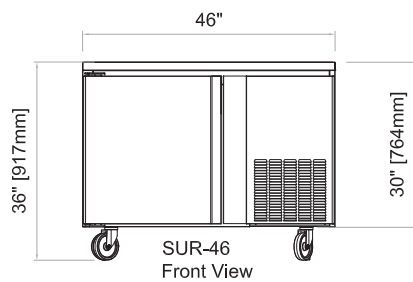

The manufacturer reserves the rights to modify materials and specifications without notice.

Printed in the USA • 09/12