



a Standex company

Item _____

HI-STYLE REFRIGERATED BAKERY CASE MODEL CGHIS-1



An attractive curved glass merchandiser that is ideal for high-turnaround with convenient product access. Designed for continuous line-ups.

STANDARD FEATURES

- Hinged thermopane curved front safety glass edged in black.
- Frameless glass-on-glass construction.
- Three cantilevered glass shelves plus three pull-out drawers for product display.
- Thermopane glass ends and rear doors.
- Rear doors and pull-out drawers are removable.
- All welded steel base construction with a choice of six standard laminates on base. Other color laminates optional.
- Satin finish stainless steel and aluminum trim. Brass and gold tone optional.
- Thermometer.
- Rear wrapping board.
- End panels and rear wrapping board are removable to allow the case to fit through a 36" door.
- Octron top light and shelf lights. Lights are shielded.
- Condensate evaporator provided for a totally self-contained system.
- Average case temperature of 38°F to 40°F is maintained.
- Easily accessible light switch and adjustable temperature control.
- Over-sized coil and low-velocity fan system maintains high humidity and product freshness.
- Pull-out refrigeration assembly for easy service.
- R134A Refrigerant.

HI-STYLE REFRIGERATED BAKERY CASE

OPTIONAL ACCESSORIES:

- | | |
|--|--|
| * Special Base Finish | * Front Package Shelf |
| * Reflective Ends | * Light Below Package Shelf |
| * Reflective Doors | * Brass & Gold Tone Trim |
| * Remote Refrigeration | * Wire Shelves |
| * Case End Panel (Per Pair,
One Pair Required For Single
Case Or Line-Up) | * Cord & Plug (Self-Contained
Models Only)(NEMA 5-15) |
| * Front Glass & Rear Door Locks | * Casters (Cord & Plug Included) |
| | * Legs |

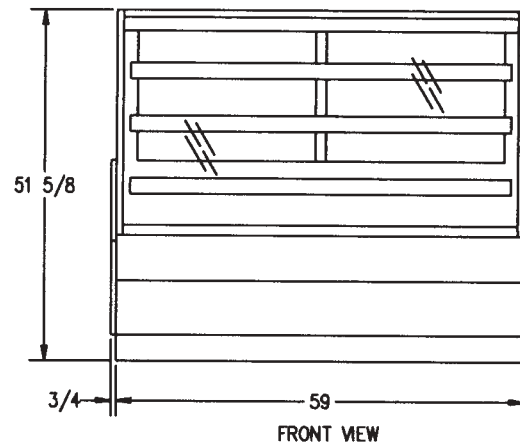
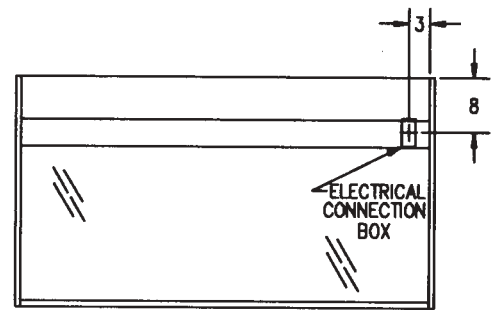
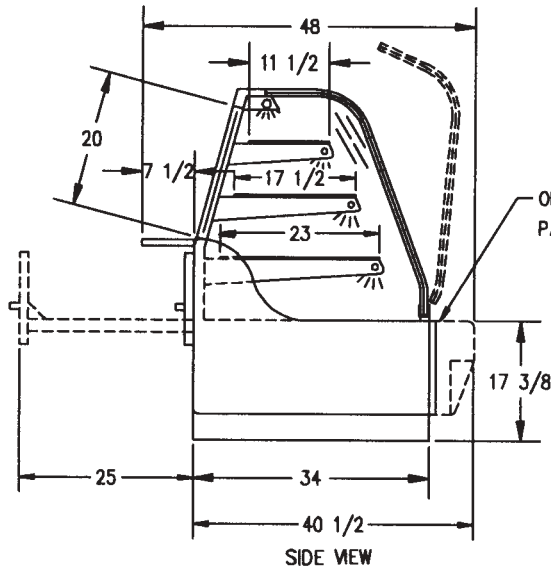

SPECIFICATIONS:

Model	Dimensions			Shipping Weight (lbs)	Capacity (Bakery Pans)	Power 120/60/1	Remote 120/60/1
	L	W	H				
CGHIS-1	59"	34"	51 5/8"	1,020	8 Full / 2 Half	1/2 HP - 12 AMPS	4.0 AMPS

- Refrigerated cases are designed to operate in a maximum environment of 75° ambient and 55% relative humidity.
- Due to continuing engineering improvements, specifications are subject to change without notice.



Look to Federal for Innovative Merchandising



a Standex company

Federal Industries
A Standex Company
215 Federal Avenue
Belleville WI 53508-0290
Phone: 800-356-4206
Fax: 608-424-3234
Email: geninfo@federalind.com
Web Site: www.federalind.com