



a Standex company

Item _____

COUNTER TOP SIGNATURE SERIES

HOT
MODEL CH2428
CH3628
CH4828



The Signature Series counter top merchandiser combines attractive curved glass styling and merchandising flexibility. Designed for continuous case line-ups. Cases are available in lengths of 2', 3', and 4'.

STANDARD FEATURES

- Curved glass styling.
- Adjustable stainless steel heated shelves. Shelves are adjustable up and down and tilted in two positions. Two tiers.
- Tempered front and end glass.
- Incandescent top and shelf lights.
- Removable sliding rear doors, shelf lights, shelf supports, and shelves.
- Stainless steel display deck.
- Easily accessible light switch and variable heat control.
- Humidified air maintains ideal product moisture.
- Stainless steel construction.
- Designed for continuous line-ups.
- Cord and plug (six foot).
- Drain not required.
- UL Safety and UL Sanitation Listed.

SIGNATURE SERIES

HOT COUNTER TOP MERCHANDISER

OPTIONAL ACCESSORIES:

- * Reflective Ends
- * Reflective Rear Doors
- * Pedestal With Wrapping Board
(To Match Refrigerated Rear Mount Unit)

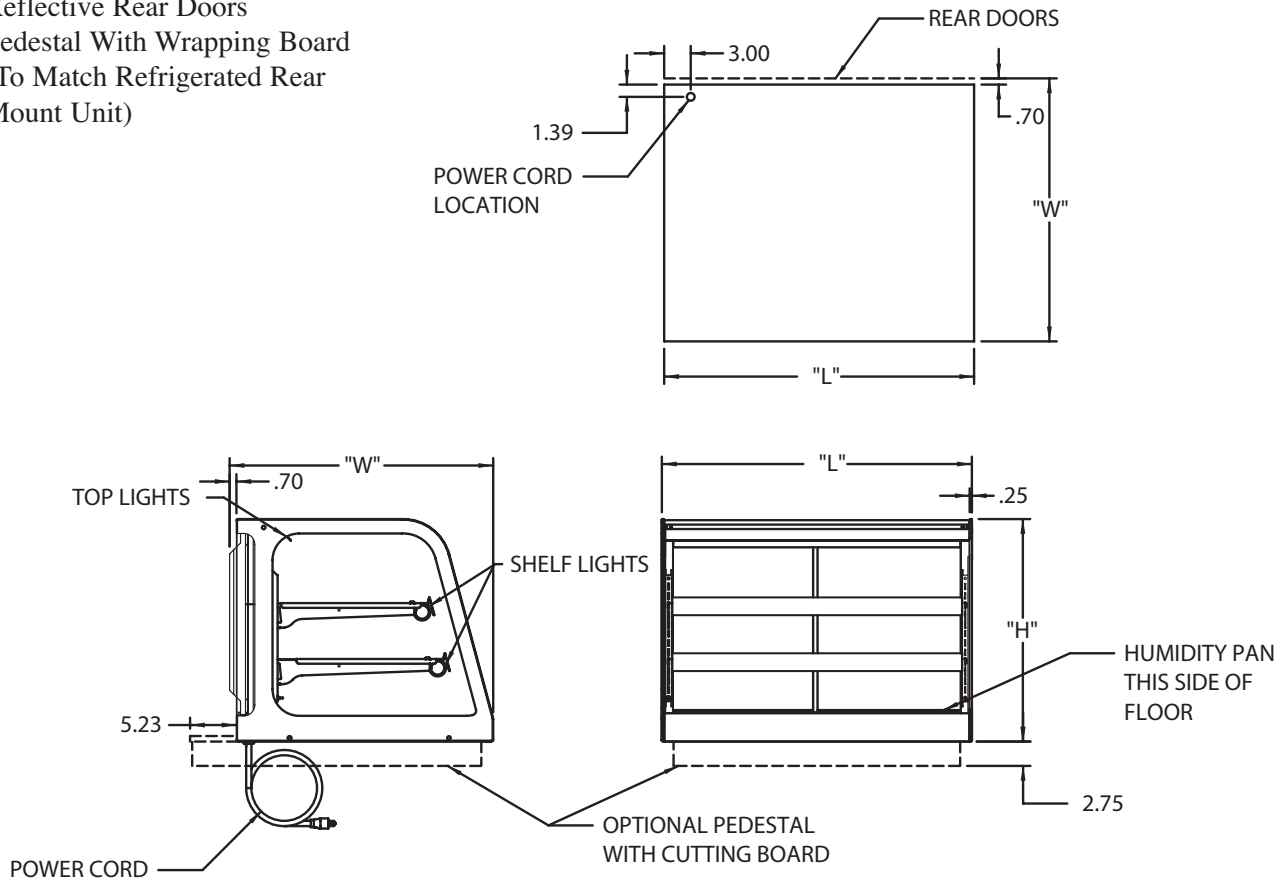

SPECIFICATIONS:

Model	Dimensions			Shipping Weight (lbs)	Electrical 120/60/1
	L	W	H		
CH2428	23"	29.7"	25.12"	290	5.8 AMPS
CH3628	35"	29.7"	25.12"	333	8.4 AMPS
CH4828	47"	29.7"	25.12"	375	11.0 AMPS

- Due to continuing engineering improvements, specifications are subject to change without notice.



Look to Federal for Innovative Merchandising



a Standex company

Federal Industries
A Standex Company
215 Federal Avenue
Belleville WI 53508-0290
Phone: 800-356-4206
Fax: 608-424-3234
Email: geninfo@federalind.com
Web Site: www.federalind.com