



a Standex company

ITEM: _____ PROJECT NAME: _____ DATE: _____

REFRIGERATED SELF-SERVE HEXAGON ISLAND MERCHANDISER

MODEL HXISS60SC



Designed with impulse sales in mind. Get maximum return and increased profits with shop-around merchandising.

STANDARD FEATURES

- Adjustable black metal shelf, one tier.
- LED top and undershelf lighting.
- Black metal base, interior and canopy. Choice of six standard laminates on exterior. Other color laminates are optional.
- Curved air deflector.
- Condensate evaporator provided for a totally self-contained system.
- Easy clean, rustproof insulated evaporator coil compartment.
- Easily accessible light switch and temperature control.
- Adjustable feet.
- Refrigeration controls maintain 40° F. Note: Case temperature will vary if the air curtain is disrupted.
- R404 Refrigerant.
- Insulated with high-density foam.
- Thermometer.
- UL Safety and UL Sanitation Listed to NSF Standard No. 7.

REFRIGERATED SELF-SERVE HEXAGON ISLAND MERCHANDISER

OPTIONAL ACCESSORIES:

- Special Color Laminated Exterior Finish
- Recessed Casters or Legs
- Cord and Plug
- Remote Refrigeration
- Condensate Pump
- Cart Bumper

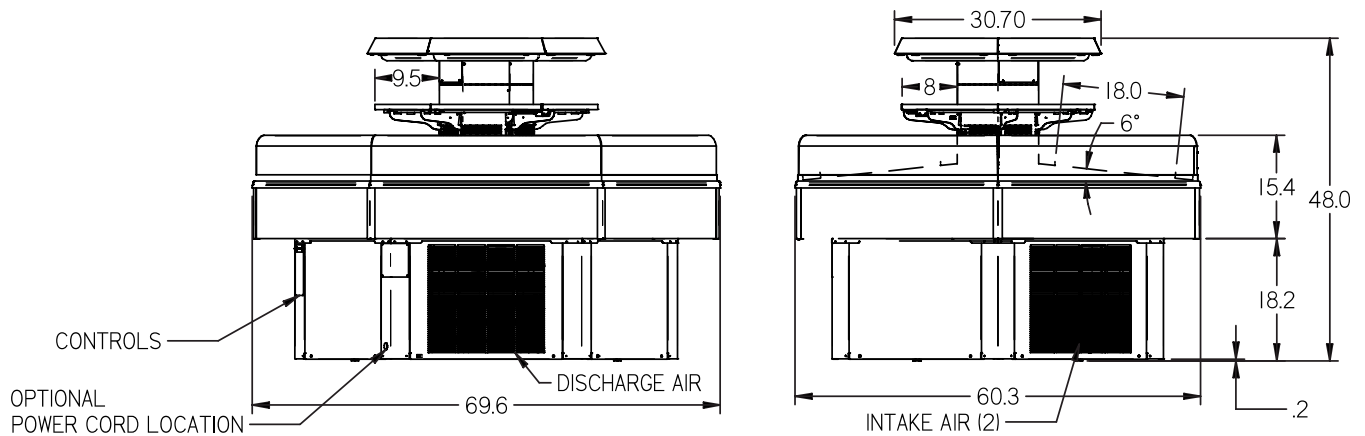
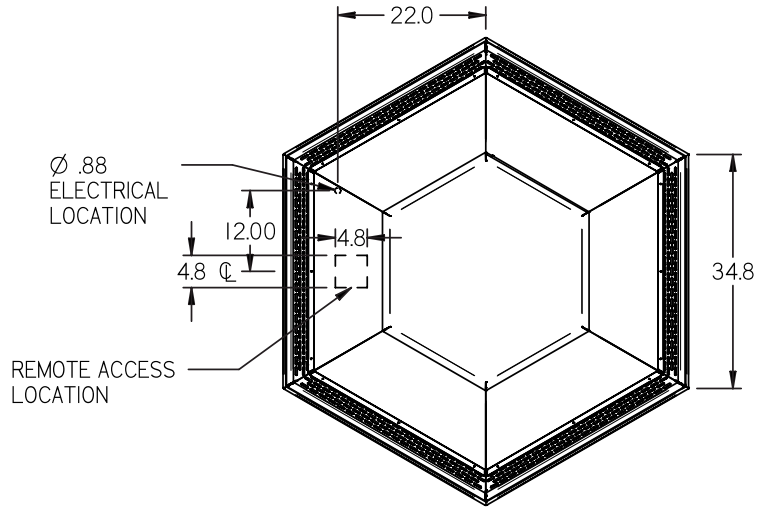

SPECIFICATIONS:

Model	Dimensions L W H	Shipping Weight (lbs)	Display Area (square feet)	Self-Contained with Condensate Pan 208-230/60/1	Remote with Condensate Pan 208-230/60/1
<input type="checkbox"/> HXISS60SC	60.3" x 69.6" x 48.0"	780	21.9	1 HP - 20 AMPS	10 AMPS

- Case temperature will vary if the air curtain is disrupted.
- Refrigerated cases are designed to operate in a maximum environment of 75°F ambient and 55% relative humidity.
- Due to continuing engineering improvements, specifications are subject to change without notice.



The Signature of Quality

FEDERAL INDUSTRIES
A Standex Company

215 FEDERAL AVENUE, BELLEVILLE, WISCONSIN 53508-9201

PHONE: 800-356-4206

EMAIL: geninfo@federalind.com

FAX: 608-424-3234

WEBSITE: www.federalind.com

