



a Standex company

ITEM: \_\_\_\_\_ PROJECT NAME: \_\_\_\_\_ DATE: \_\_\_\_\_

## REFRIGERATED SELF-SERVE LOW PROFILE SPECIALTY MERCHANDISER

- MODEL  LPRSS3  
 LPRSS4  
 LPRSS5  
 LPRSS6



*Maximize your display potential with Federal's low-profile, refrigerated self-serve merchandiser. Bring product to the customer for increased sales with the reduced labor of a self-serve display case. Available in lengths of 3', 4', 5', and 6'.*

### STANDARD FEATURES

- Steel base construction with choice of six standard laminates on exterior. Other finishes optional.
- Black trim.
- Two tiers adjustable solid black metal shelves.
- Stainless steel display deck and black interior ends and back panel. Glass end panels.
- Horizontal top light. Undershelf lights are optional.
- On-demand PTC condensate evaporator provided for a totally self-contained system. A condensate pump is required on the LPRSS5 and LPRSS6 and remote cases.
- Easily cleaned, rustproof, insulated evaporator coil compartment.
- Insulated with high-density foam.
- Rear access to the refrigeration system for quick easy service.
- Easily accessible light switch, power switch, and adjustable temperature control.
- Energy-saving night curtain.
- Electronic temperature control maintains 38° to 40°F with on-demand defrost.
- R404 Refrigerant.
- Thermometer provided.
- Adjustable feet.
- Continuous line-ups are available for remote applications.
- Cord and plug.
- UL Safety and UL Sanitation listed.
- DOE 2012 Compliant.

# REFRIGERATED SELF-SERVE LOW PROFILE SPECIALTY MERCHANDISER

## OPTIONAL ACCESSORIES:

- Special Base Finish
- Lights Below Shelves
- LED Lighting
- Casters: Recessed or Exposed
- Legs
- Remote Refrigeration
- Solid Rear Sliding Access Doors
- Two-Tier Display Step in Lieu of Shelving
- Glass or Stainless Shelving in Lieu of Black Metal
- Flush End Panels for Counter Installations
- Joining Kit for Continuous Line-ups
- Reflective End Glass
- Stainless Steel Interior, Including Shelves
- Security Night Cover
- Front Non-Refrigerated Display Merchandiser
- Front or Rear Condensing Unit Air Discharge
- Condensate Pump
- Condensate Evaporator Assembly (Field Install, Dedicated Circuit)

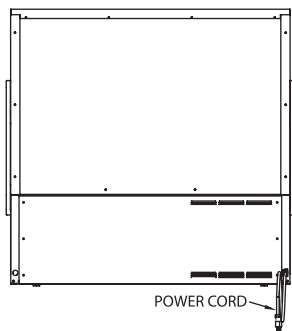

REAR VIEW

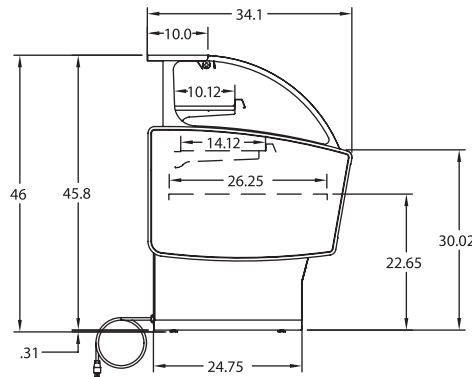

END VIEW

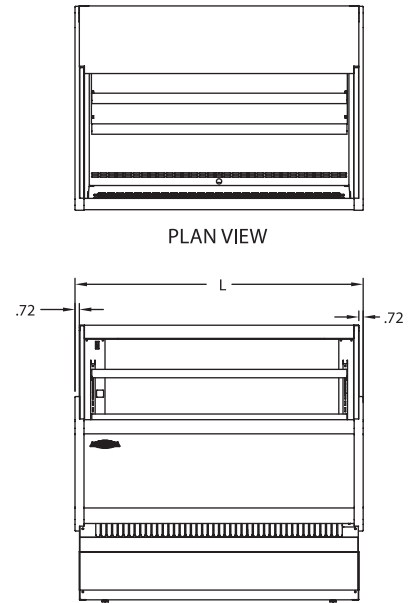

FRONT VIEW

PLAN VIEW

## SPECIFICATIONS:

Model	Dimensions L W H	Shipping Weight (lbs)	Shelf Area (Square Feet)	Self-Contained with Condensate Pan 208-230/60/1	Remote with Condensate Pump 120/60/1
<input type="checkbox"/> LPRSS3	36" x 34" x 46"	457	11	120/60/1 • 1/3 HP • 16 AMPS	2 AMPS
<input type="checkbox"/> LPRSS4	48" x 34" x 46"	560	15	120/60/1 • 1/3 HP • 16 AMPS	2 AMPS
<input type="checkbox"/> LPRSS5	60" x 34" x 46"	650	19	230/60/1 • 1/2 HP • 9 AMPS	3 AMPS
<input type="checkbox"/> LPRSS6	72" x 34" x 46"	750	24	230/60/1 • 3/4 HP • 10 AMPS	3 AMPS

- Case temperature will vary if the air curtain is disrupted.
- The rear of the unit needs to be 6" from a wall.
- Refrigerated cases are designed to operate in a maximum environment of 75°F ambient and 55% relative humidity.
- Due to continuing engineering improvements, specifications are subject to change without notice.



*The Signature of Quality*

**FEDERAL INDUSTRIES**  
A Standex Company

215 FEDERAL AVENUE, BELLEVILLE, WISCONSIN 53508-9201

PHONE: 800-356-4206

EMAIL: [geninfo@federalind.com](mailto:geninfo@federalind.com)

FAX: 608-424-3234

WEBSITE: [www.federalind.com](http://www.federalind.com)

