



a Standex company

ITEM: \_\_\_\_\_ PROJECT NAME: \_\_\_\_\_ DATE: \_\_\_\_\_

## SERIES '90 REFRIGERATED DELI CASE

MODEL  SN-4CD  
 SN-6CD  
 SN-8CD



*Series '90. The ultimate merchandiser with advanced styling for maximum visual appeal. Cases are available in lengths of 4', 6', and 8'. Designed for continuous case line-ups.*

### STANDARD FEATURES

- Lift-up pneumatic, cylinder-assisted, double-curve tempered front glass.
- Four-point leveling system.
- Removable sliding rear doors and mezzanine shelf.
- Glass ends and rear doors. Rear doors are sloped for product access.
- Octron top light and mezzanine shelf lights. Lights are shielded and independently wired.
- All-welded base construction with a choice of six standard laminates on base. Other finishes optional.
- Easily accessible control panel with main power switch, light switch, digital thermometer, and adjustable temperature control.
- Base trim: specify white, black, or stainless.
- End glass trim: specify white or black.
- Double-bend tempered front glass reduces glare from outside lighting.
- Case height is only 48" high allowing better interaction between the customer and the sales clerk.
- White display deck and mezzanine shelf. On the four- and six-foot model, one full-length mezzanine shelf is provided. The eight-foot model comes with two four-foot shelves.
- Condensate evaporator for a totally self-contained system.
- Average case temperature of 36° to 38°F is maintained without condensation on the front glass.
- Over-sized coil and low-velocity fan system maintains high humidity and product freshness.
- Pull-out condensing unit for quick and easy service.
- Rear wrapping board.
- Appliance receptacle provided on the back of the case for a cash register, scale, or slicer.
- R134A Refrigerant.
- UL Safety and UL Sanitation Listed.

# SERIES '90 REFRIGERATED DELI CASE

## OPTIONAL ACCESSORIES:

- Special Base Finish
- Base Trim Specify White, Black, or Stainless
- End Glass Trim Specify White or Black
- Black or Stainless Steel Interior
- Glass or Stainless Steel Mezzanine Shelf
- Additional Mezzanine Shelf With Light
- LED or Promolux Lighting
- Casters or Legs
- Cord and Plug (Six Foot)
- Front Package Shelf With or Without Light Below
- Reflective End Glass
- Mirrored Interior Ends With Laminated Exterior
- Reflective Rear Doors
- Front Glass and Rear Door Locks
- Top Service Shelf (Stainless Steel or Glass)
- Step Pan Holder or Riser
- Scale Stand
- Fish Case Package (Includes Ice Pan and Drain)
- Remote Refrigeration
- Condensate Pump

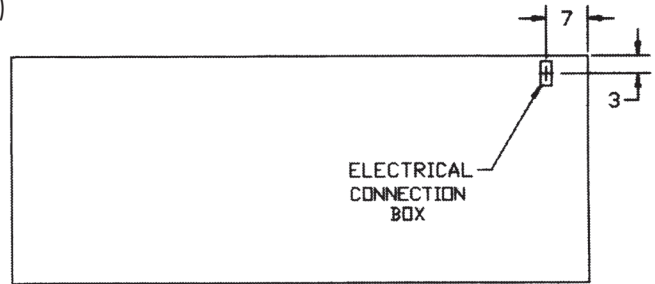

PLAN VIEW

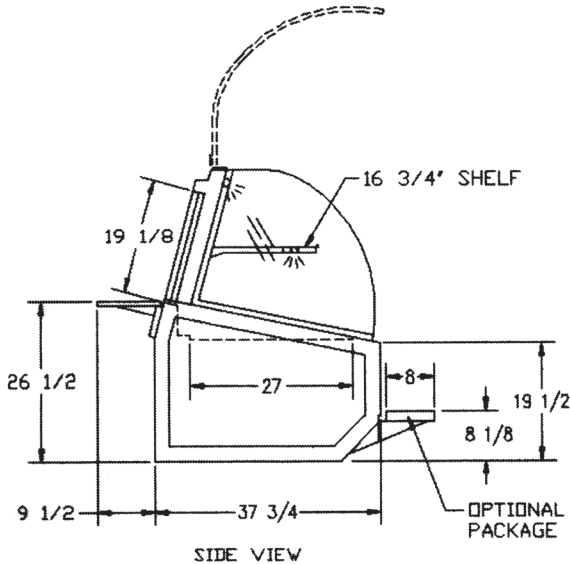

SIDE VIEW

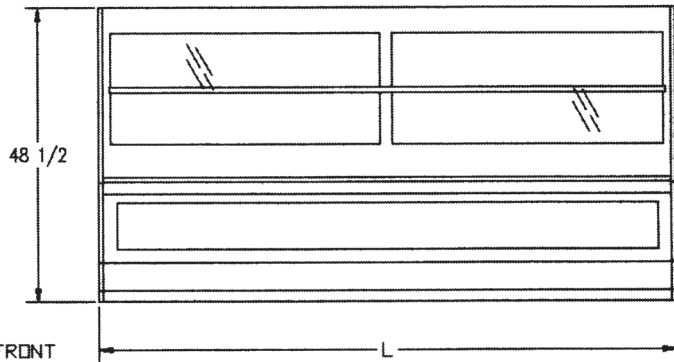

FRONT VIEW

## SPECIFICATIONS:

Model	Dimensions L W H	Shipping Weight (lbs)	Capacity (Step Pans)	*Self-Contained 120/60/1	Remote 120/60/1
<input type="checkbox"/> SN-4CD	48 1/4" x 37 3/4" x 48 1/2"	770	3	1/2 HP • 12 AMPS	13.2 AMPS
<input type="checkbox"/> SN-6CD	72 1/4" x 37 3/4" x 48 1/2"	1,000	5	3/4 HP • 15 AMPS	16.1 AMPS
<input type="checkbox"/> SN-8CD	96 1/2" x 37 3/4" x 48 1/2"	1,265	7	3/4 HP • 16 AMPS	17.2 AMPS

\*Plus general purpose receptacle 120V, 15AMP. (Not available with caster option.)

- Cases are designed to operate in a maximum environment of 75° ambient and 55% relative humidity.
- Due to continuing engineering improvements, specifications are subject to change without notice.



*The Signature of Quality*

**FEDERAL INDUSTRIES**  
A Standex Company

215 FEDERAL AVENUE, BELLEVILLE, WISCONSIN 53508-9201

PHONE: 800-356-4206

EMAIL: geninfo@federalind.com

FAX: 608-424-3234

WEBSITE: www.federalind.com

