



a Standex company

ITEM: \_\_\_\_\_ PROJECT NAME: \_\_\_\_\_ DATE: \_\_\_\_\_

## MARKET SERIES REFRIGERATED BAKERY CASE

- MODEL  SQ-3CB  
 SQ-4CB  
 SQ-5CB  
 SQ-6CB  
 SQ-8CB



Panel base shown

*Market Bakery. The low profile merchandiser that provides solutions to your merchandising needs. Cases are available in lengths of 3', 4', 5', 6', and 8'.  
Designed for continuous case line-ups without middle end glass.*

### STANDARD FEATURES

- Lift-up, pneumatic, cylinder-assisted curved front glass.
- Four-point leveling system.
- Rear work counter.
- Octron top light and shelf lights. Lights are shielded and independently wired.
- Two tiers tempered glass shelves.
- Pedestal or panel base design.
- Tempered front and end glass.
- **Removable rear door assembly. Doors not required for operation.**
- Stainless steel interior and exterior finish.
- Solid-state control panel with main power, light, and temperature readout: humidity control optional.
- Condensate evaporator provided for a totally self-contained system. Remote refrigeration available.
- **Average case temperature of 38° to 40°F is maintained in the bottom display area. Glass shelves are non-refrigerated.**
- Oversized coil and low-velocity fan system maintains high humidity and product freshness.
- UL Safety and UL Sanitation Listed.
- Designed for continuous case line-ups.
- Full length, two step deck display risers.
- Appliance receptacle provided on back.

# MARKET SERIES REFRIGERATED BAKERY CASE

## OPTIONAL ACCESSORIES:

- Special Case Height (50" or 52")
- Front Bumper Rail (Black, White, Green, Gray)
- Reflective End Glass
- Decorative End Panel (Black, White, Green, Gray)
- Remote Refrigeration
- Top Service Shelf
- Humidity Control
- Accent Base Light
- Promolux Lighting
- Condensate Pump

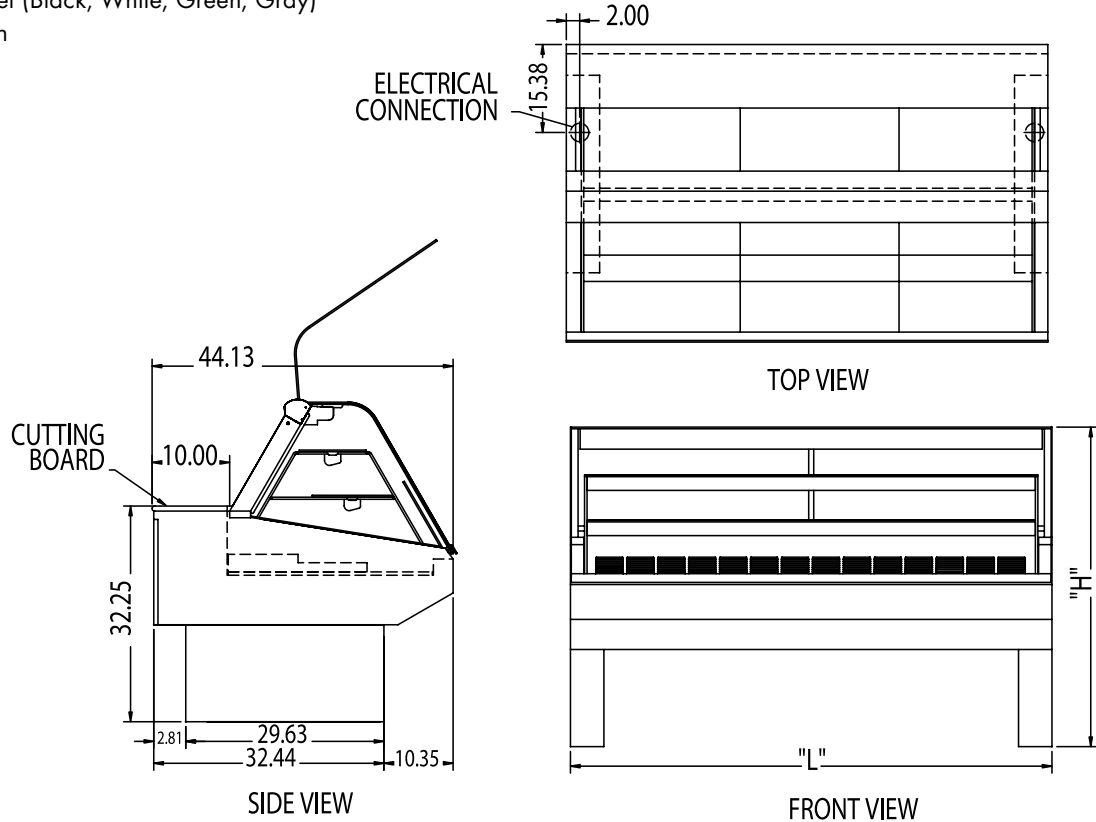

## SPECIFICATIONS:

Model	*Dimensions L W H	Approx. Shipping Weight (lbs)	** Self-Contained 120/60/1	** Remote 120/60/1
<input type="checkbox"/> SQ-3CB	36" x 44 1/8" x 48"	790	1/2 HP • 11.5 AMPS	6 AMPS
<input type="checkbox"/> SQ-4CB	48" x 44 1/8" x 48"	795	1/2 HP • 13.8 AMPS	7 AMPS
<input type="checkbox"/> SQ-5CB	60" x 44 1/8" x 48"	845	1/2 HP • 13.8 AMPS	7 AMPS
<input type="checkbox"/> SQ-6CB	72" x 44 1/8" x 48"	1,135	1/2 HP • 14.8 AMPS	7 AMPS
<input type="checkbox"/> SQ-8CB	96" x 44 1/8" x 48"	1,235	3/4 HP • 16.0 AMPS	8 AMPS

\* Without decorative end panel.

\*\* Plus general receptacle 120V, 15 AMP. (2nd circuit required.)

- **When ordering, specify case line-up and pedestal or panel design.**
- Refrigerated cases are designed to operate in an environment of 75° ambient and 55% relative humidity.
- Due to continuing engineering improvements, specifications are subject to change without notice.
- **Refrigerated bottom display deck, non-refrigerated shelves.**



*The Signature of Quality*

**FEDERAL INDUSTRIES**  
A Standex Company

215 FEDERAL AVENUE, BELLEVILLE, WISCONSIN 53508-9201

PHONE: 800-356-4206

EMAIL: geninfo@federalind.com

FAX: 608-424-3234

WEBSITE: www.federalind.com

