



a Standex company

ITEM: _____ PROJECT NAME: _____ DATE: _____

MARKET SERIES SELF-SERVE REFRIGERATED BAKERY CASE

- MODEL SQ-3CBSS
 SQ-4CBSS
 SQ-5CBSS
 SQ-6CBSS
 SQ-8CBSS



Panel base shown

Market Bakery. The merchandiser that provides solutions to your merchandising needs. Cases are available in lengths of 3', 4', 5', 6', and 8'. Designed for continuous case line-ups.

STANDARD FEATURES

- Four-point leveling system.
- Rear work counter.
- Octron case light.
- Pedestal or panel base design.
- Stainless steel interior and exterior finish.
- Solid-state control panel with main power, light, and temperature readout.
- Condensate pump provided.
- Appliance receptacle provided on back.
- Average case temperature of 38° to 40°F is maintained.
- UL Safety and UL Sanitation Listed.
- Designed for continuous case line-ups.
- Full length, two step deck display risers.
- Energy-saving night curtain.

MARKET SERIES SELF-SERVE REFRIGERATED BAKERY CASE

OPTIONAL ACCESSORIES:

- Special Case Height (34" or 38")
- Front Bumper Rail (Black, White, Green, Gray)
- Remote Refrigeration
- Decorative End Panel (Black, White, Green, Gray)
- Accent Base Light
- Promolux Lighting
- Condensate Evaporator Assembly

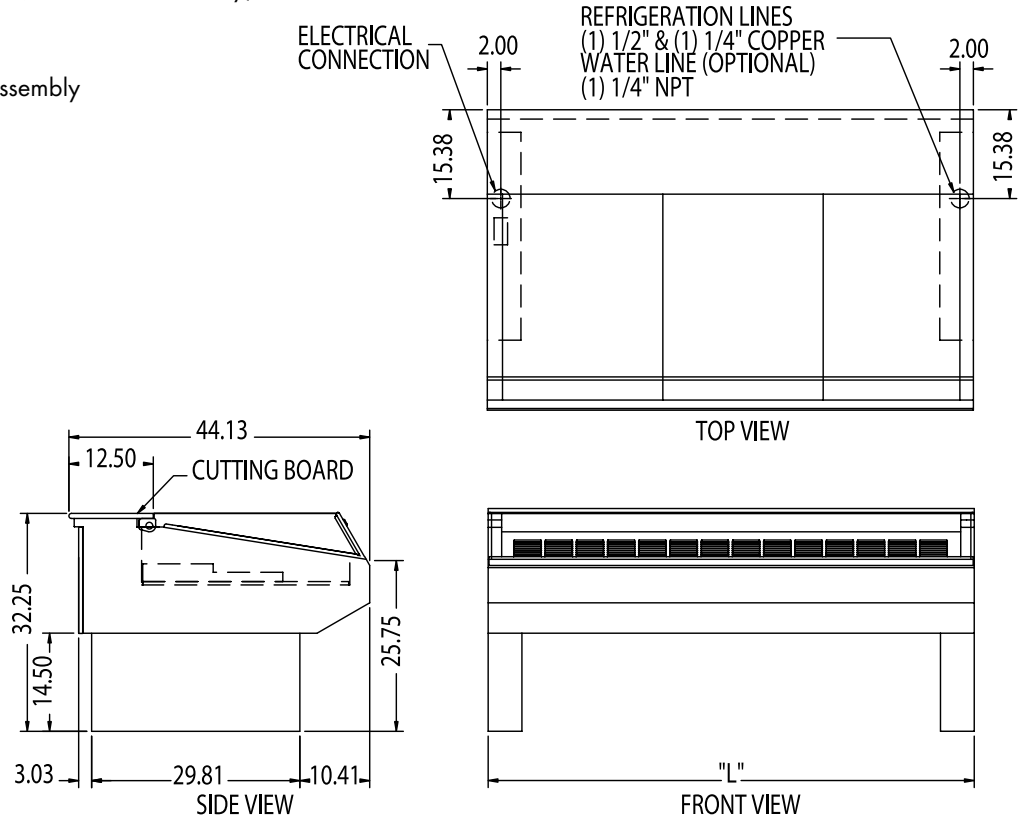

SPECIFICATIONS:

Model	*Dimensions L W H	Approx. Shipping Weight (lbs)	** Self-Contained 120/60/1	** Remote 120/60/1
<input type="checkbox"/> SQ-3CBSS	36" x 44 1/8" x 32 1/4"	675	1/2 HP • 11.5 AMPS	6 AMPS
<input type="checkbox"/> SQ-4CBSS	48" x 44 1/8" x 32 1/4"	745	1/2 HP • 13.8 AMPS	7 AMPS
<input type="checkbox"/> SQ-5CBSS	60" x 44 1/8" x 32 1/4"	895	1/2 HP • 13.8 AMPS	7 AMPS
<input type="checkbox"/> SQ-6CBSS	72" x 44 1/8" x 32 1/4"	1,035	1/2 HP • 14.8 AMPS	7 AMPS
<input type="checkbox"/> SQ-8CBSS	96" x 44 1/8" x 32 1/4"	1,135	3/4 HP • 16.0 AMPS	8 AMPS

* Without decorative end panel.

** Plus general receptacle 120V, 15 AMP. (2nd circuit required.)

• **When ordering, specify case line-up and pedestal or panel design.**

• Cases are designed to operate in an environment of 75° ambient and 55% relative humidity.

• Due to continuing engineering improvements, specifications are subject to change without notice.



The Signature of Quality

FEDERAL INDUSTRIES

A Standex Company

215 FEDERAL AVENUE, BELLEVILLE, WISCONSIN 53508-9201

PHONE: 800-356-4206

EMAIL: geninfo@federalind.com

FAX: 608-424-3234

WEBSITE: www.federalind.com

