



EXTRACTOR COFFEE BREWER

CBS 2030 Series

CBS-2031e

1 Gallon Brewer



Versatile and reliable, .5 to 1 gallon brewers are the perfect solution for small- to medium-sized operations. CBS-2031e comes standard with our patented Cascading Spray Dome™, which helps deliver a consistent, perfectly balanced cup of coffee every time. You can conveniently use lightweight, portable airpots or our LUXUS® Thermal Servers to keep coffee hot for hours.

Brewer shown with the 1.0 Gallon LUXUS® Thermal Server (L3S-10). The 3.0 Liter Stainless Steel Lined Lever Airpot and the 1.9 Liter Stainless Steel Lined Server are also available. All are sold separately.



Cascading Spray Dome™ technology ensures perfect extraction of coffee flavor.

Pulse-Brew System delivers intermittent pulses of water to ensure even saturation of the coffee bed for enhanced extraction.



Digital Interface makes it easy to program and run brewer. Settings can be customized to your recipe.

Pre-Wet Cycle allows you to control the length of time water is in contact with the coffee before the brew cycle to ensure optimum flavor.



Bypass Feature redirects water directly into the dispenser, bypassing the coffee grounds in the brew basket, to provide your custom water-to-coffee ratio.

Brew Time & Brew Volume can be programmed separately to ensure a perfectly-balanced batch, no matter how much coffee you brew at once.



Drip Delay lets you set the time between the end of the brew cycle and the unlocking of the brew basket, for increased safety.

FETCO

DRIVEN TO INNOVATION

Water Specification

Water Inlet 3/8" Male Flare	Minimum Flow Rate 1/4 gpm [1 lpm]	Water Pressure 20-75 psig [139-517 kPa]
--------------------------------	--------------------------------------	--

Electrical Configuration

Configuration Code	Heater Configuration	Voltage	Phase	Wires	KW	Electrical Connection	Max Amp Draw	Gallon[Liter]/Hour
DOMESTIC & CANADA								
E31015 ⁽¹⁾	1 x 2.3 kW	120	1	2+G	2.4	5-20P	19.7	5.8 [22.0] ⁽²⁾
	2 x 2.3 kW	120/208-240	1	3+G	3.6-4.7	Hardwired	17.1-19.7	9.0-11.8 [34.0-44.7] ⁽²⁾
E31035 ⁽¹⁾	1 x 1.7 kW	120	1	2+G	1.8	5-20P	19.7	4.4 [16.7] ⁽²⁾
	2 x 1.7 kW	120/208-240	1	3+G	2.7-3.5	Hardwired	17.1-19.7	6.7-8.8 [25.0-33.0] ⁽²⁾
E31045 ⁽¹⁾	1 x 1.5 kW	120	1	2+G	1.6	5-15P	13.0	3.9 [14.8] ⁽²⁾
	2 x 1.5 kW	120/208-240	1	3+G	2.4-3.1	Hardwired	11.3-13.0	6.1-7.7 [23.1-29.0] ⁽²⁾
EXPORT								
E31025	1 x 3.0 kW	220-240	1	2+G	2.6-3.1	Hardwired	12.0-13.0	6.4-7.7 [24.3-29.3] ⁽²⁾

Important

- (1) Can be connected to 120 VAC (Factory Setting) or 120/208-240 VAC.
- (2) Based on standard factory settings: 4.0 minute brew time; 0% prewet; 200°F water.

Measurements

Height 26 1/8" [66.4 cm]	Width 11" [27.9 cm]	Depth 17 7/8" [45.4 cm]	Empty Weight 35 lbs [15.9 kg]	Filled Weight 60 lbs [27.2 kg]	Shipping Weight 42 lbs [19.0 kg]
-----------------------------	------------------------	----------------------------	----------------------------------	-----------------------------------	-------------------------------------

SIDE VIEW

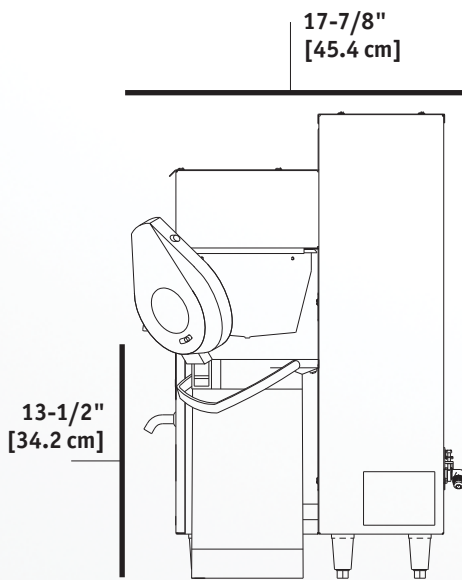

FRONT VIEW

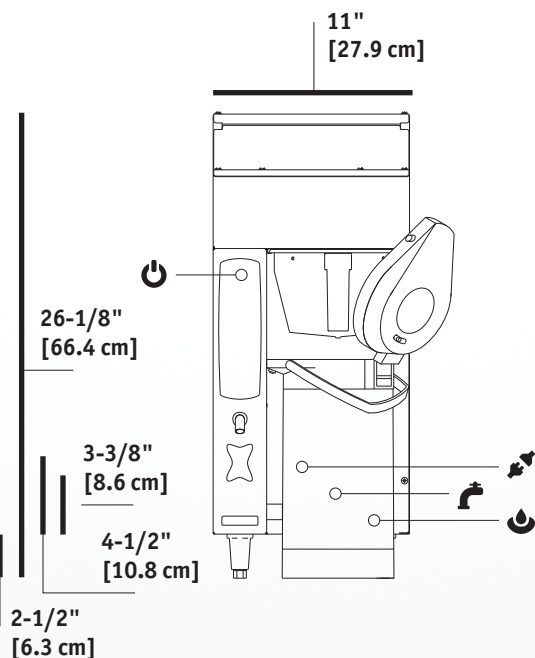

SYMBOLS

- Electrical Connector
- On / Off Switch
- Tank Drain
- Water Inlet

NEMA PLUGS CONFIGURATIONS

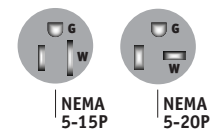

DISPENSERS

Brewer can be used with:
L3S-10 Thermal Dispenser
with Serving Station L3S-10

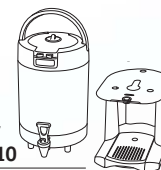

1.9 Liter Stainless Steel
Lined Server



3.0 Liter Stainless Steel
Lined Lever Airpot

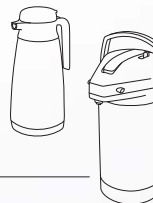

FETCO® is an active member of



Information

www.fetco.com

+1 847.719.3000
1.800.338.2699 USA
+1 847.719.3001

Food Equipment Technologies Co.
600 Rose Road
Lake Zurich, IL 60047
USA