



3.0 GALLON COFFEE BREWING SYSTEM

CBS-2160 TOUCHSCREEN SERIES

The 3.0 Gallon CBS-2161 / 2162 XTS Touchscreen Series Coffee Brewers provide flexibility in large sized venues such as Banquet Halls, Large Hotels and Catering Operations. Simplify your daily operations and experience total control of this fully featured Extractor® Brewing System via an inviting touchscreen interface display that is intuitive, easy to read and simple to navigate.



CBS-2161XTS
Single Station Brewer*



CBS-2162XTS
Dual Station Brewer*

* Shown with TPD-30 Luxus® Dispenser (sold separately)

Perfect taste begins with a simple touch...

User Friendly Touchscreen

Access all controls via an inviting touchscreen interface display that blends intuitive icons with dynamic time and volume data to provide instant visual feedback at any point during programming, diagnostics or the brew cycle.

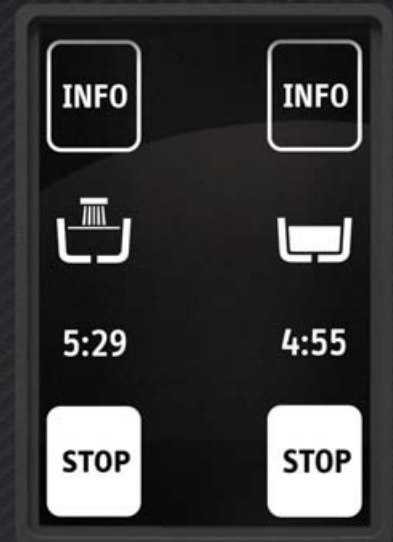

Streamlined Programming, Diagnostics and Metrics

The Extractor® Touchscreen Operating System (ETOS) was engineered for quick and efficient navigation through set-up, programming, diagnostics and daily operational brewing modes.



Customizable Screens

Customize the start screen to tie your equipment and product offerings into a consistent brand message. You can also create and display individual recipe names for quick and easy access to your most used coffee blends.



XTS™ Series

Driven by a user friendly touchscreen interface and intuitive software, the XTS series represents the next step in the evolution of FETCO's renown EXTRACTOR® brewing technology.



Cascading Spray Dome™

Hot tank water flows over clog-free channels built into the dome and virtually eliminates spray head scale buildup – a leading reason for service calls.

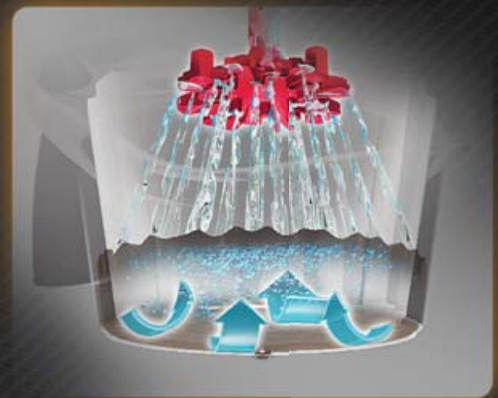

Legendary Extractor® Control

Take your coffee to its peak level by unlocking the full freshness, aroma and flavor of your taste profile with the legendary EXTRACTOR® brewing technology.

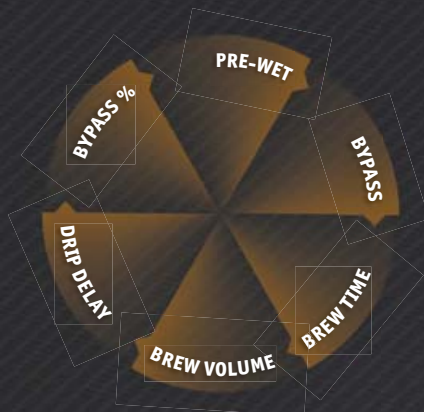

Contemporary Design

Sleek European cabinet design is attractive and fits well in most front-of-house decor typically found in coffee shops, lounges and cafes.



Modern Convenience

Duplicate profiles and parameters to and from any of the batch buttons on a single machine or copy the information to an unlimited number of brewers via a removable SD card (Sold separately).



Luxus® Dispensing

The portable LUXUS® Series Thermal Dispensers feature high-quality stainless-steel vacuum liners for optimum retention of heat, freshness and flavor.

TPD-30 LUXUS®
Thermal Dispenser



Water Specification

Water Inlet
3/8" male flare fitting

Minimum Flow Rate
2 gpm [7.6 lpm]

Water Pressure
20-75 psig [138-517 kPa]

Electrical Configuration

Configuration Code	Heater Configuration	Voltage	Phase	Wires	KW	Electrical Connection	Max Amp Draw	Gallon [Liter] / Hour
US & CANADA								
E216151 ⁽²⁾	3 X 3.0 kW	200-240	3	3L+G	6.4-9.1	Terminal Block	18.6-22.5	16.4-23.4 [62.0-88.0] ⁽¹⁾
Optional ⁽³⁾	2 X 3.0 kW	200-240	1	2L+G	4.6-6.1	Terminal Block	21.2-25.8	11.8-15.7 [44.0-59.0] ⁽¹⁾
E216152 ⁽²⁾	3 X 4.0 kW	200-240	3	3L+G	8.4-12.1	Terminal Block	24.7-28.9	21.6-30.0 [82.0-113.0] ⁽¹⁾
Optional ⁽³⁾	2 X 4.0 kW	200-240	1	2L+G	6.1-8.1	Terminal Block	28.1-33.8	15.6-20.8 [59.0-79.0] ⁽¹⁾
E216153 ⁽²⁾	3 X 5.0 kW	200-240	3	3L+G	10.5-15.1	Terminal Block	30.7-36.1	27.0-30.0 [102.0-113.0] ⁽¹⁾
Optional ⁽³⁾	2 X 5.0 kW	200-240	1	2L+G	7.6-10.1	Terminal Block	35.1-42.2	19.6-26.0 [74.0-98.0] ⁽¹⁾

(1) Based on standard factory settings: 5.5 minute brew time; 0% prewet; 200°F water. 3 gallons per batch.

(2) Sold as three phase, highest power version.

(3) Equipment may be field configurable to lower-power, single-phase configuration using two heaters.

Cups per Hour*

8oz. **480**

12oz. **320**

16oz. **240**

20oz. **192**

* Approximate based on maximum power setting.

Compatible Dispensers

#D012
TPD-30
3.0 Gallon LUXUS®
Portable Thermal
Dispenser

Product DIMS:
Height: 25 1/2" [64.5 cm]
Width: 11" [27.9 cm]
Depth: 15 1/2" [35.6 cm]
Weight:
Empty: 18.1 lbs [8.2 kg]
Filled: 42.5 lbs [19.3 kg]



#D009
TPD-15
1.5 Gallon LUXUS®
Portable Thermal
Dispenser

Product DIMS:
Height: 24 1/8" [61.3 cm]
Width: 9 5/16" [23.7 cm]
Depth: 13 7/8" [35.2 cm]
Weight:
Empty: 12.8 lbs [5.8 kg]
Filled: 24.7 lbs [11.2 kg]



Coffee Filter

#F004
20" x 8"
Standard Paper Coffee Filter

#F005
18 1/2" x 7 1/2"
Half-Batch Paper Coffee Filter



Brew Basket

#B00828004
21" x 7"
Stainless Steel

#B00828002
21" x 7"
Stainless Steel
with Clips*

*(clips not shown)



#B00828003
18" x 7 1/2"
Stainless Steel
Half Batch



↔ Measurements

Height	Width	Depth	Empty Weight	Filled Weight	Combined Filled Weight	Hot Water Tank Cap.	Shipping Weight	Shipping Dimensions
41 ¹ / ₄ " [104.8 cm]	17 ⁷ / ₈ " [45.4 cm]	22 ¹ / ₂ " [57.0 cm]	88 lbs [40.0 kg]	160 lbs [72.5 kg]	202.5 lbs [92.0 kg] BREWER + 1 FILLED TPD-30 DISPENSER	8.7 gal [33.0 l]	96 lbs [44.0 kg]	40" x 24" x 27" [101.6 x 61.0 x 68.6 cm]

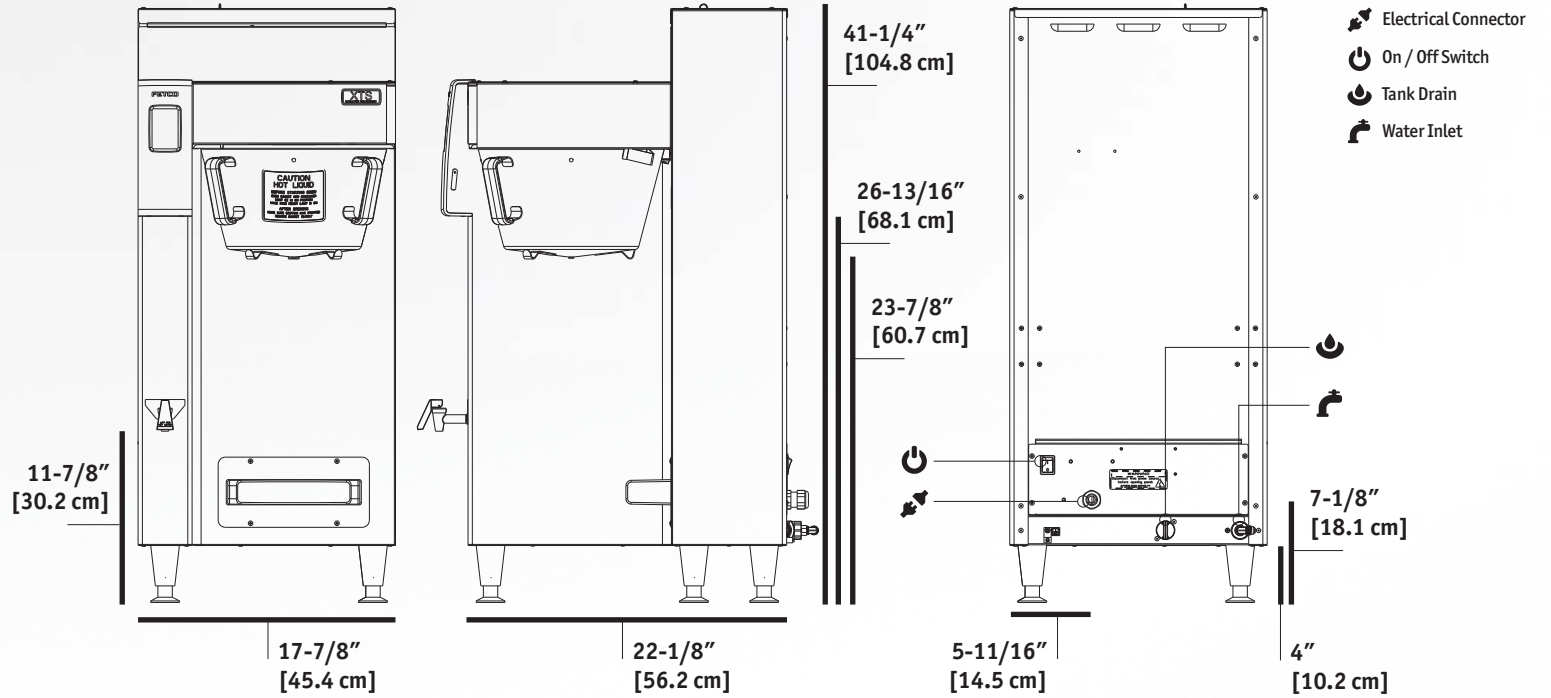

🖼️ Gallery



Water Specification

Water Inlet
3/8" male flare fitting

Minimum Flow Rate
2 gpm [7.6 lpm]

Water Pressure
20-75 psig [138-517 kPa]

Electrical Configuration

Configuration Code	Heater Configuration	Voltage	Phase	Wires	KW	Electrical Connection	Max Amp Draw	Gallon [Liter] / Hour
US & CANADA								
E216251	3 X 3.0 kW	200-240	3	3L+G	6.4-9.1	Terminal Block	18.6-22.5	16.4-23.4 [62.0-88.0] ⁽¹⁾
E216252	6 X 3.0 kW	200-240	3	3L+G	12.6-18.1	Terminal Block	36.4-43.7	32.4-46.5 [123.0-176.0] ⁽¹⁾
E216253	3 X 4.0 kW	200-240	3	3L+G	8.4-12.1	Terminal Block	24.7-28.9	21.6-31.2 [82.0-118.0] ⁽¹⁾
E216254	6 X 4.0 kW	200-240	3	3L+G	16.8-24.1	Terminal Block	48.4-58.1	43.1-60.0 [163.0-227.0] ⁽¹⁾
E216271	6 X 4.0 kW	440-480	3	3L+G	20.3-24.1	Terminal Block	26.6-29.4	52.2- 60.0 [197.0- 227.0] ⁽¹⁾

(1) Based on standard factory settings: 5.5 minute brew time; 0% prewet; 200°F water. 3 gallons per batch.

Cups per Hour*

8oz. **960**

12oz. **640**

16oz. **480**

20oz. **384**

* Approximate based on maximum power setting.

Compatible Dispensers

#D012
TPD-30
3.0 Gallon LUXUS®
Portable Thermal
Dispenser

Product DIMS:
Height: 25 1/2" [64.5 cm]
Width: 11" [27.9 cm]
Depth: 15 1/2" [35.6 cm]
Weight:
Empty: 18.1 lbs [8.2 kg]
Filled: 42.5 lbs [19.3 kg]



#D009
TPD-15
1.5 Gallon LUXUS®
Portable Thermal
Dispenser

Product DIMS:
Height: 24 1/8" [61.3 cm]
Width: 9 5/16" [23.7 cm]
Depth: 13 7/8" [35.2 cm]
Weight:
Empty: 12.8 lbs [5.8 kg]
Filled: 24.7 lbs [11.2 kg]



Coffee Filter

#F004
20" x 8"
Standard Paper Coffee Filter

#F005
18 1/2" x 7 1/2"
Half-Batch Paper Coffee Filter



Brew Basket

#B00828004
21" x 7"
Stainless Steel

#B00828002
21" x 7"
Stainless Steel
with Clips*

*(clips not shown)



#B00828003
18" x 7 1/2"
Stainless Steel
Half Batch



← Measurements

Height	Width	Depth	Empty Weight	Filled Weight	Combined Filled Weight	Hot Water Tank Cap.	Shipping Weight	Shipping Dimensions
41 ¹ / ₄ " [104.8 cm]	32" [81.3 cm]	22 ¹ / ₂ " [57.0 cm]	130 lbs [59.0 kg]	266 lbs [120.7 kg]	349 lbs [158.3 kg] BREWERS + 1 FILLED TPD-30 DISPENSER	16.3 gal [62.0 l]	140 lbs [63.6 kg]	37" x 22" x 27" [94.0 x 55.9 x 68.6 cm]

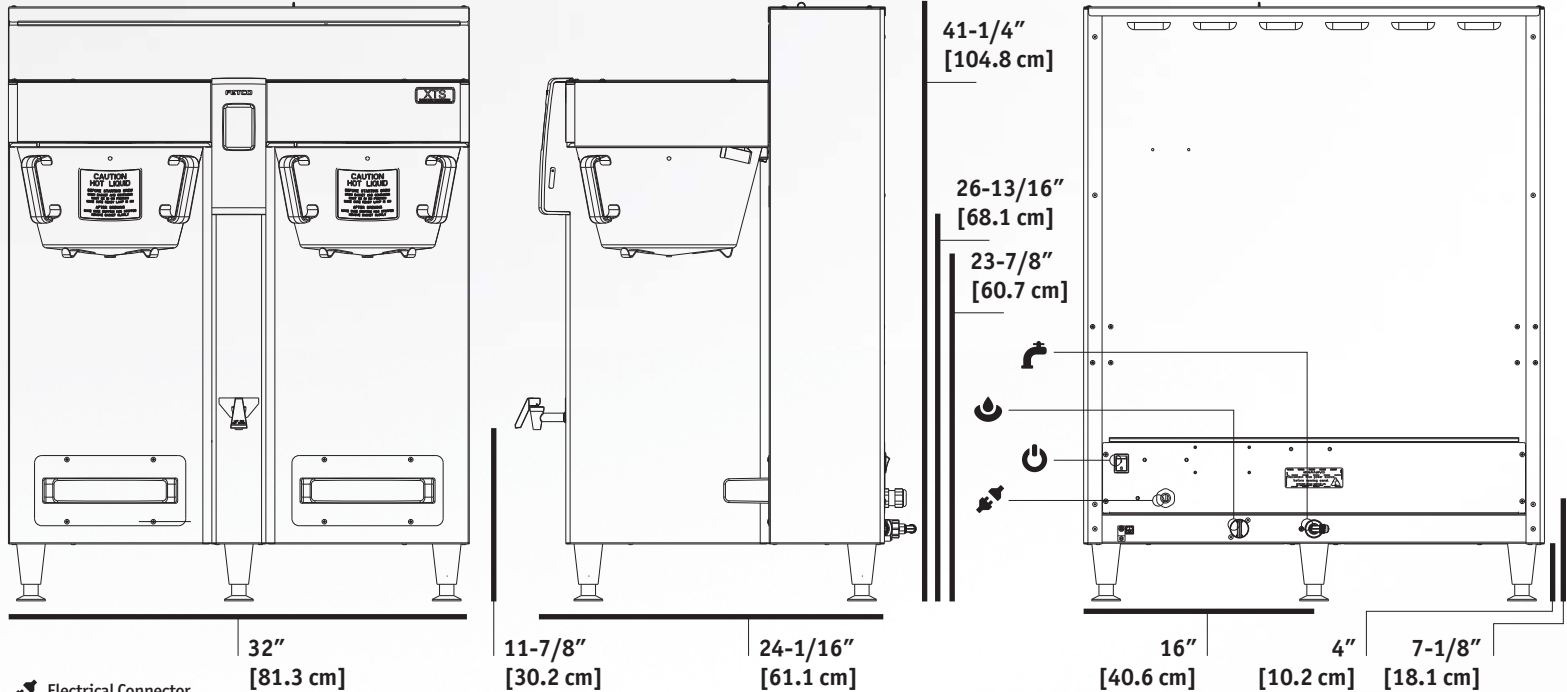

- Electrical Connector
- On / Off Switch
- Tank Drain
- Water Inlet

Gallery



Features & Benefits



Feature	Benefit
1 Touchscreen Interface	Allows for quick and easy access to brew controls.
2 Brew Basket Sensors	Automatically discontinues operation of brew cycle if basket is removed.
3 Reversible Dispenser Guide	Reversible 2-sided guide accommodates both 1.5G and 3.0G TPD Dispensers.
4 Manual Water Faucet	Safely dispenses hot water away from steam and brew basket.
5 Stainless Steel Finish	Withstands the harshest foodservice environments and is durable and easy to clean.

Dispensers sold separately.

 fetco.com

 800.338.2699 USA
847.719.3000

 847.719.3001

 Food Equipment Technologies Co.
600 Rose Road
Lake Zurich, IL 60047
USA