

**APPLICATION:**

**JOB NAME:**

**QUANTITY:**      **ITEM NO.**

**PRODUCT NAME:**

**FILLKING**

**SPECIAL CONFIGURATION**  
**CHECK BASE MODEL AND OPTIONS**

**MODEL:**

**14087**

**OPTIONS OR MODIFICATIONS:**

**3/4" ANGLE STOPS**

**6' SUPPLY LINES**

**OTHER**

**FEATURES:**

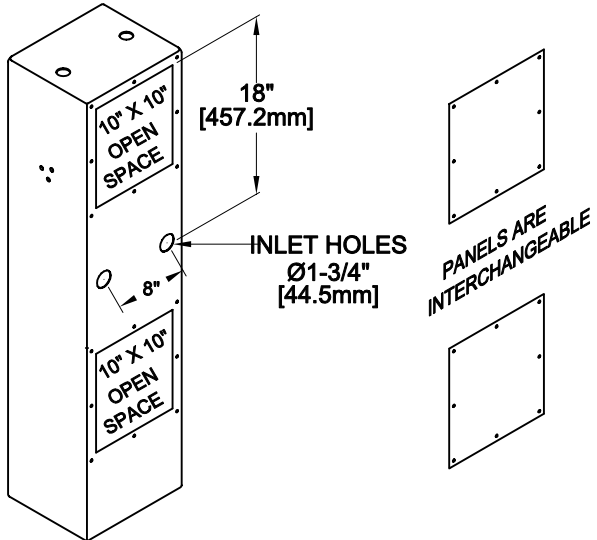
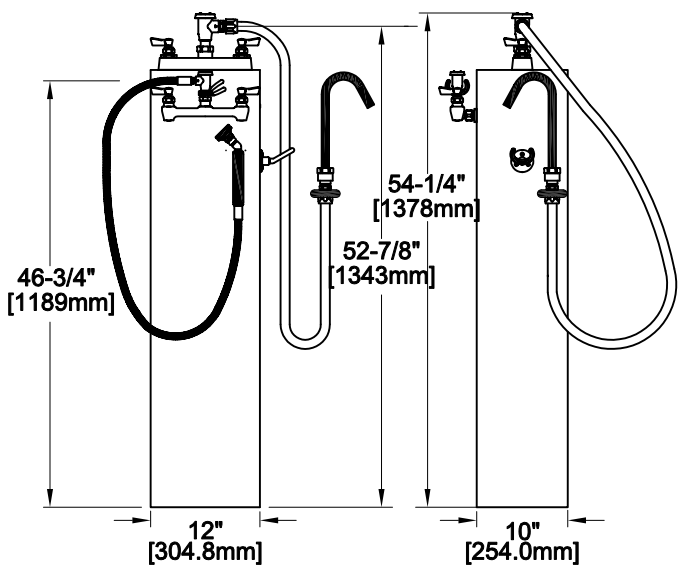

**ROUGH-IN: SEE THE BOTTOM OF THIS BOX**

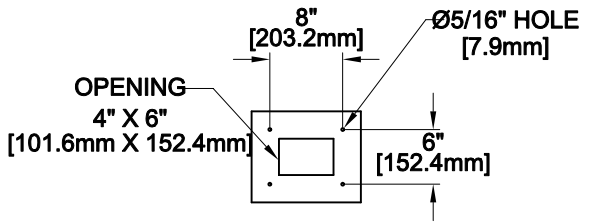

**CONTROL VALVES**

- \* 3/4" POT FILLER - DECK MOUNT FAUCET
- \* 1/2" UTILITY - BACK SPLASH MOUNTED FAUCET

**BOTH CONTROL VALVES LISTED ABOVE HAVE THE FOLLOWING FEATURES:**

- \* INTERNAL SPRING LOADED CHECK VALVES
- \* SWIVELING SEAT DISKS
- \* HOT SIDE STEM - RIGHT HAND
- \* COLD SIDE STEM - LEFT HAND
- \* STAINLESS STEEL SEATS
- \* STAINLESS STEEL SEAT SCREWS
- \* STAINLESS STEEL HANDLE SCREWS

**3/4" POT FILLER HOSE**

- \* 72" LG. HEAT MASTER FDA NITRILE/ARAMID
- \* NSF-51 (100 PSI W.P. AT 300°F) CONSTANT
- \* RENEWABLE END FITTINGS AND BUMPER
- \* INLET - 360° SWIVEL VACUUM BREAKER
- \* OUTLET - 360° SWIVEL SPOUT W/ VINYL FINISH

**1/2" UTILITY HOSE**

- \* 84" LG. 3-PLY FIBER REINFORCED RUBBER
- \* STAINLESS STEEL EXTERNAL JACKET
- \* STAINLESS STEEL RENEWABLE END FITTINGS
- \* INLET - SWIVEL VACUUM BREAKER
- \* OUTLET - 45° SPRAY HEAD
- \* SHOWER SPRAY PATTERN
- \* THERMAL INSULATED HANDLE

**CABINET**

- \* STAINLESS STEEL TOWER W/ INTERNAL FLOOR MOUNT FLANGE
- \* INTERCHANGEABLE ACCESS PANELS FOR INSTALLATION AND MAINTENANCE

**SYSTEM LIMITS:**

- \* TEMP: 40°F MIN. TO 140°F MAX.
- \* PRESSURE: 100 PSI MAX. WORKING
- \* 3/4" POT FILLER: 40 GPM AT 80 PSI
- \* 1/2" UTILITY SPRAY: 2.65 GPM AT 80 PSI

**SHIPPING WEIGHT**

- \* 78.0 LBS