

APPLICATION:

PRODUCT NAME:

VACUUM BREAKER ANTI-SPILL
SATIN CHROME

JOB NAME:

_____ SPECIAL CONFIGURATION
(CHECK BASE MODEL AND OPTIONS)

QUANTITY:

ITEM NO.

MODEL:
 14443

OPTIONS OR MODIFICATIONS

OTHER _____

FEATURES:

- * ANTI-SPILL DESIGN
- * ASSE - 1056 APPROVED

SYSTEM LIMITS

- * TEMP: 33°F MIN. TO 180°F MAX.
- * PRESSURE 8 PSI MIN. TO 150 PSI MAX.

SHIPPING WEIGHT

- * 2.0 LBS

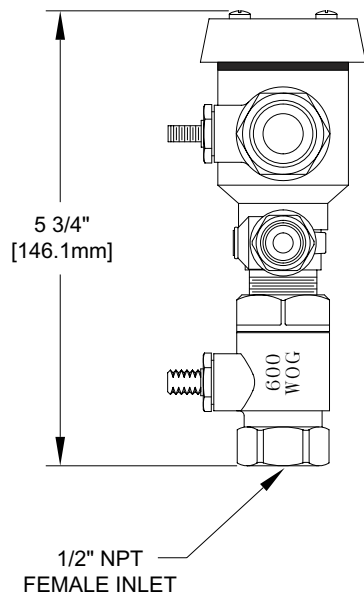
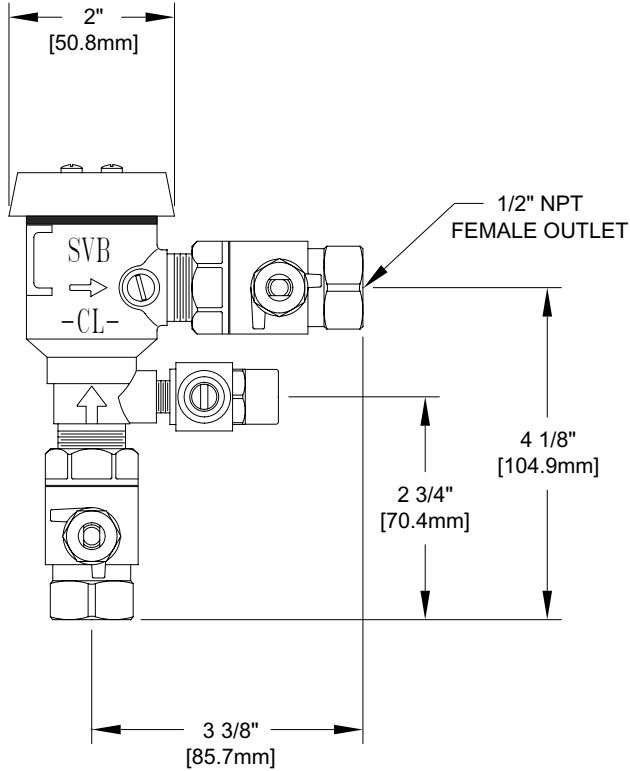

ANSI/A112.18.1M

FISHER

FISHER MANUFACTURING COMPANY
TOLL FREE: 800-421-6162 - FAX: 800-832-8238
information@fisher-mfg.com - www.fisher-mfg.com