

APPLICATION:

JOB NAME:

QUANTITY: **ITEM NO.**

PRODUCT NAME:
 PRE-RINSE, SWIVEL STYLE,
 DECK MOUNT

_____ **SPECIAL CONFIGURATION**
 CHECK BASE MODEL AND OPTIONS

MODEL:

2311 **ULTRA SPRAY VALVE NO WALL BRACKET**

2311-WB **ULTRA SPRAY VALVE W/ WALL BRACKET**

OPTIONS OR MODIFICATIONS:

SUPPLY LINES (24" OR 36") CIRCLE LENGTH

ADD-ON FAUCET (6", 8", 10", 12", 14", 16") CIRCLE

IN-LINE DUAL CHECK VALVE

PIPE HOOK

BRUSH

HANDLES (CROSS OR WRIST) CIRCLE STYLE

VANDAL RESISTANT KIT

OTHER _____

FEATURES

CONTROL VALVE

- * 8" DECK MOUNT
- * INTERNAL SPRING LOADED CHECK VALVES
- * HOT SIDE STEM - RIGHT HAND
- * COLD SIDE STEM - LEFT HAND
- * SWIVELLING SEAT DISKS
- * STAINLESS STEEL SEATS
- * STAINLESS STEEL SEAT SCREWS
- * STAINLESS STEEL HANDLE SCREWS

HOSE

- * 15-1/2" LENGTH
- * STAINLESS STEEL END FITTINGS
- * STAINLESS STEEL EXTERNAL JACKET
- * 3-PLY FIBER REINFORCED INTERNAL RUBBER HOSE

ULTRA SPRAY VALVE

- * LOWEST ENERGY USER - 1.15 GPM @ 60 PSI
- * CLEANS FASTER - TEST PROVEN
- * ENGINEERED TO LAST - NO 'O' RINGS TO LEAK
- * INTERCHANGEABLE - FITS ALL BRANDS

SYSTEM LIMITS

- * TEMP: 40°F MIN. TO 140°F MAX.
- * PRESSURE: 200 PSI MAX. STATIC

SHIPPING WEIGHT

- * 12.0 LBS

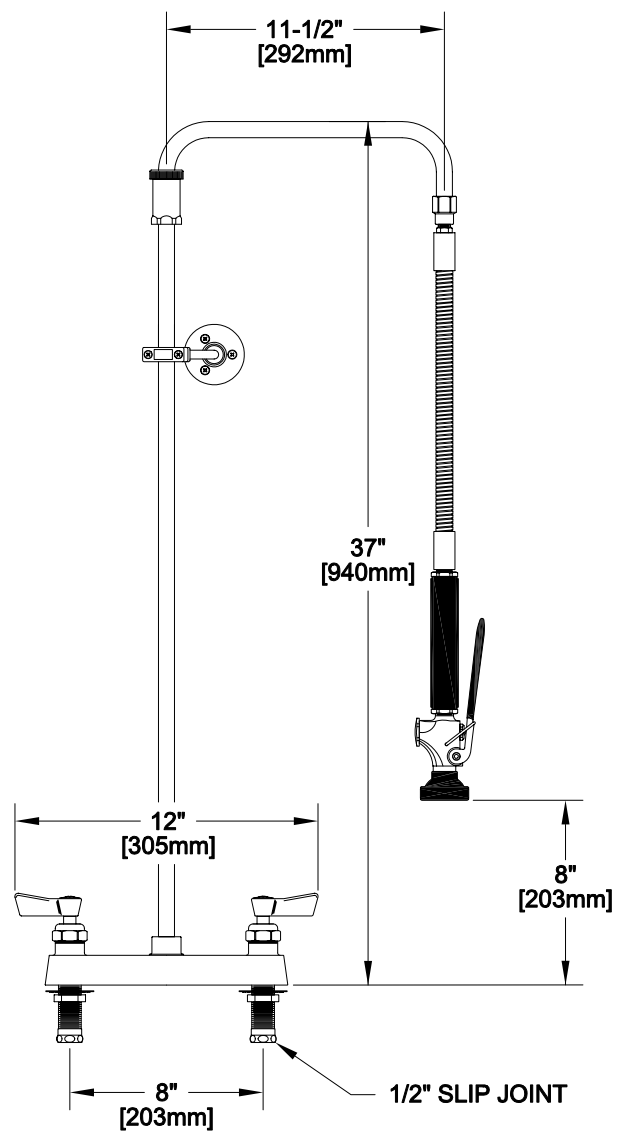

ROUGH-IN:

