

PRODUCT NAME:

TROUGH INLET FITTING - 1/2" INLET

_____ SPECIAL CONFIGURATION
(CHECK BASE MODEL AND OPTIONS)

MODEL:

2905

OPTIONS OR MODIFICATIONS:

OTHER _____

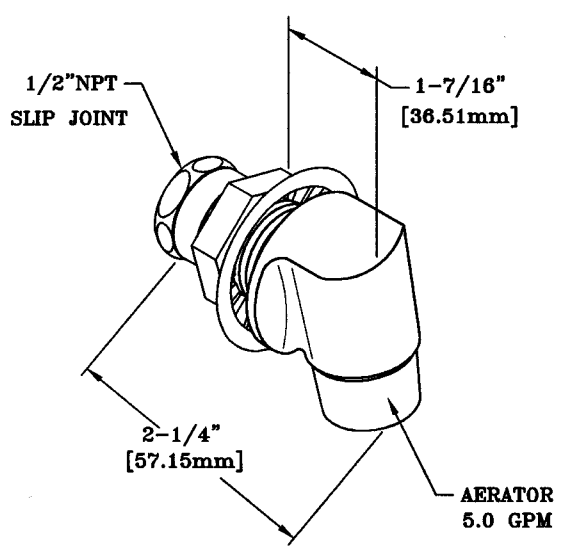

RECOMMENDED SETTINGS

* 110°F AT 80 PSI

SYSTEM LIMITS

* TEMP: 40°F MIN. TO 140°F MAX.
* PRESSURE 200 PSI MAX. STATIC

SHIPPING WEIGHT

* .5 LB

ROUGH-IN:

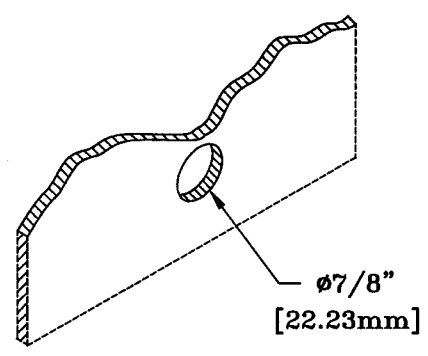

ANSI/A112.18.1M

FISHER MANUFACTURING COMPANY