

APPLICATION:

JOB NAME:

QUANTITY: **ITEM NO.**

PRODUCT NAME:

**STAINLESS STEEL REEL RINSE
CLOSED WITH SPRAY GUN**

_____ **SPECIAL CONFIGURATION
CHECK BASE MODEL AND OPTIONS**

MODEL:

29637 W/ 35' LENGTH HOSE

29629 W/ 50' LENGTH HOSE

OPTIONS OR MODIFICATIONS:

SUPPLY LINES (24" OR 36") CIRCLE LENGTH

ADD-ON FAUCET (6", 8", 10", 12", 14", 16") CIRCLE

IN-LINE DUAL CHECK VALVE

HANDLES (CROSS OR WRIST) CIRCLE STYLE

VANDAL RESISTANT KIT

OTHER _____

FEATURES:

REEL RINSE

- * CLOSED DESIGN
- * STAINLESS STEEL CONSTRUCTION
- * ADJUSTABLE GUIDE SLEEVE
- * RATCHET LOCK AND EASY TENSION ADJUST
- * STAINLESS STEEL OR BRASS FLUID PATH

HOSE

- * 35' OR 50' LENGTH REEL HOSE
- * 5/8" ID HIGH TEMPERATURE HOSE
- * 3-PLY FIBER REINFORCED
- * 1/2" F NPT OR 3/4" F GARDEN HOSE INLET
- * 18" LENGTH INLET HOSE
- * ADJUSTABLE BALL STOP

SPRAY GUN

- * STAINLESS STEEL CONSTRUCTION
- * WATERPROOF NYLON COVER
- * ERGONOMIC DESIGN
- * LOCKING TRIGGER MECHANISM
- * 7.0 GPM AT 80 PSI

SYSTEM LIMITS

- * TEMP: 40°F MIN. TO 140°F MAX.
- * PRESSURE 150 PSI MAX. STATIC

SHIPPING WEIGHT

- * 29637 - 62.0 LBS
- * 29629 - 70.0 LBS

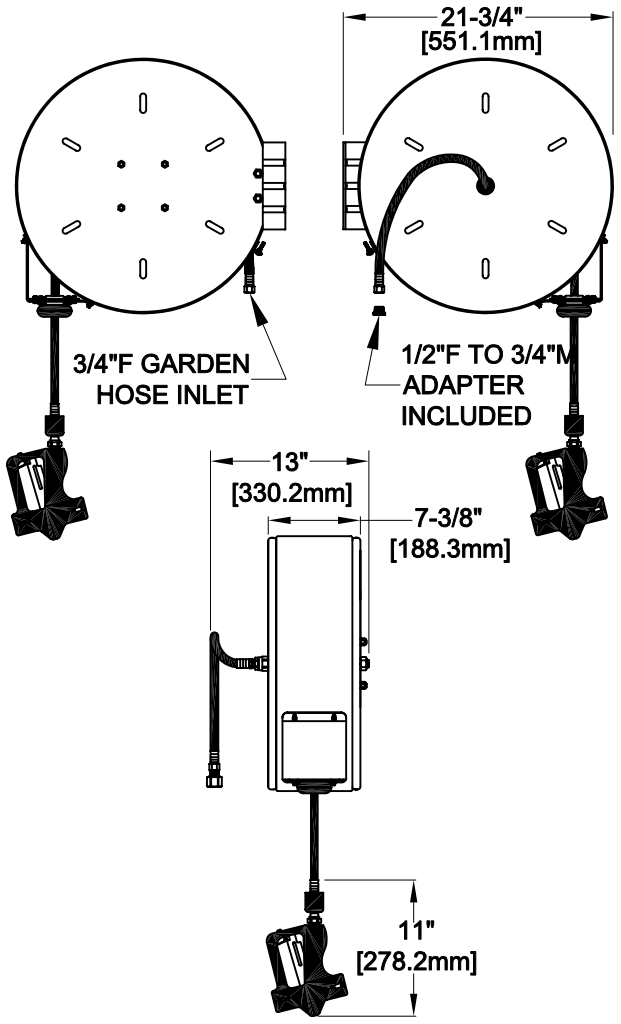

ROUGH-IN: SEE MOUNTING PLATE BELOW

