

APPLICATION:

JOB NAME:

QUANTITY: ITEM NO.

PRODUCT NAME:

REEL RINSE UNDER
COUNTER MOUNT

SPECIAL CONFIGURATION
CHECK BASE MODEL AND OPTIONS

MODEL:

2984 WITH 12' HOSE

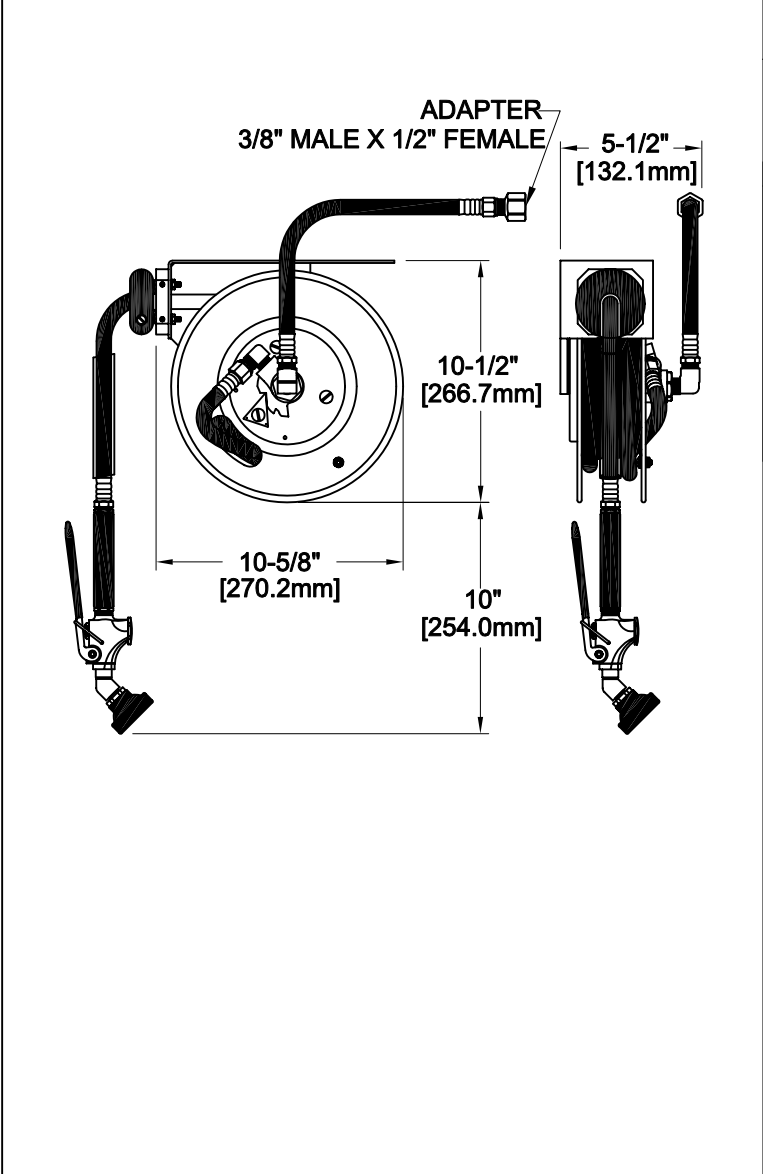

OPTIONS OR MODIFICATIONS:

BRUSH

OTHER _____

FEATURES:

REEL

- * SELF LOCKING
- * EXPOSED

HOSE

- * 12' LENGTH REEL HOSE
- * 19" LENGTH INLET HOSE
- * 3-PLY FIBER REINFORCED RUBBER HOSE
- * ADJUSTABLE BALL STOP

STANDARD SPRAY VALVE

- * NOZZLE THREADED INTO VALVE
- * 2.65 GPM AT 80 PSI
- * SHOWER SPRAY PATTERN

SYSTEM LIMITS

- * TEMP: 40°F MIN. TO 140°F MAX.
- * PRESSURE 200 PSI MAX. STATIC

SHIPPING WEIGHT

- * 13.0 LBS

ROUGH-IN: SEE MOUNTING PLATE BELOW

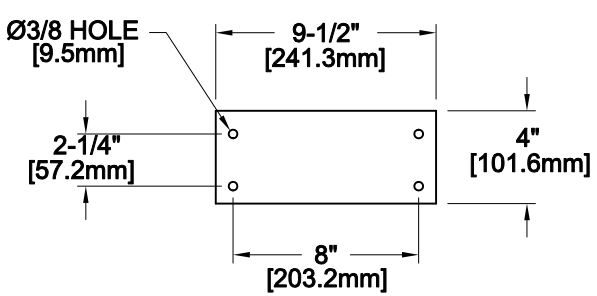

FISHER

FISHER MANUFACTURING COMPANY

TOLL FREE: 800-421-6162 - FAX: 800-832-8238

information@fisher-mfg.com - www.fisher-mfg.com