

APPLICATION:

JOB NAME:

QUANTITY: ITEM NO.

PRODUCT NAME:
DIPPERWELL FAUCET & SINK ASSEMBLY

SPECIAL CONFIGURATION
 CHECK BASE MODEL AND OPTIONS

MODEL:
 3041

OPTIONS OR MODIFICATIONS:
 OTHER _____

FEATURES:

DIPPERWELL FAUCET
 * STAINLESS STEEL SEAT

DIPPERWELL SINK
 * STAINLESS STEEL PAN
 * REMOVABLE INNER SHELL

SYSTEM LIMITS
 * TEMP: 40°F MIN. TO 140°F MAX.
 * PRESSURE 200 PSI MAX. STATIC

SHIPPING WEIGHT
 * 3.5 LBS

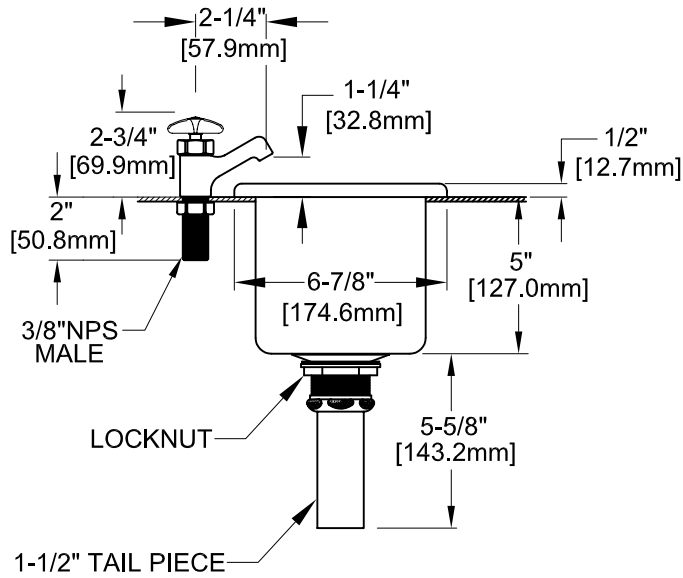

ROUGH-IN:

