

PRODUCT NAME:

DIPPERWELL SINK ASSEMBLY

PRODUCT #

3043

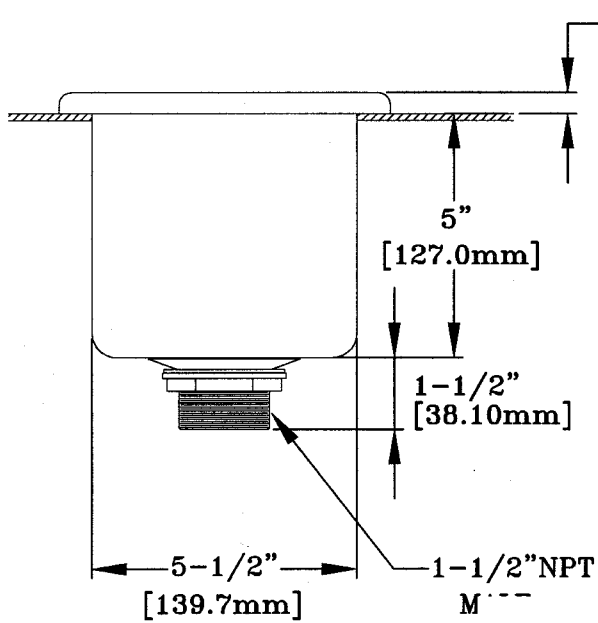

OPTIONS OR MODIFICATIONS:

OTHER _____

FEATURES:

- * STAINLESS STEEL PAN
- * REMOVABLE INNER SHELL

SHIPPING WEIGHT

- * 2.0 LBS

ROUGH-IN:

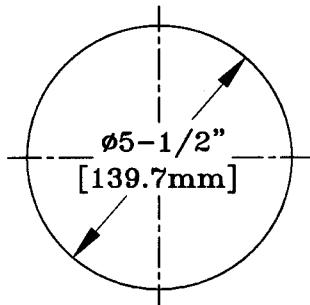

ANSI/A112.18.1M

FISHER MANUFACTURING COMPANY