

APPLICATION:

PRODUCT NAME:  
ATMOSPHERIC VACUUM  
BREAKER

JOB NAME:

SPECIAL CONFIGURATION  
CHECK BASE MODEL AND OPTIONS

QUANTITY:

ITEM NO.

MODEL:  
 3990

OPTIONS OR MODIFICATIONS:  
 SUPPLY LINES (24" OR 36") CIRCLE LENGTH  
 OTHER \_\_\_\_\_

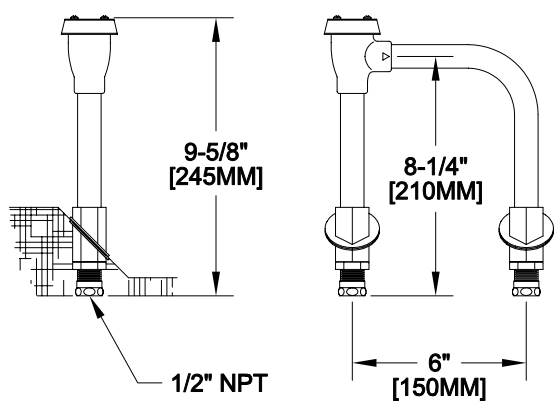

FEATURES

- \* ATMOSPHERIC VACUUM BREAKER
- \* LEDGE MOUNT

SYSTEM LIMITS

- \* TEMP: 40°F MIN. TO 140°F MAX.
- \* PRESSURE: 200 PSI MAX. STATIC

SHIPPING WEIGHT

\* 3.5 LBS

ROUGH-IN:

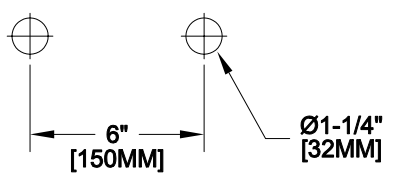

FISHER MANUFACTURING COMPANY  
 TOLL FREE: 800-421-6162 - FAX: 800-832-8238  
 information@fisher-mfg.com - www.fisher-mfg.com