

APPLICATION: PRODUCT NAME:
8" C/C BACKSPLASH PRE-RINSE

JOB NAME: ■ 80764 SPECIAL CONFIGURATION (CHECK BASE MODEL AND OPTIONS)

QUANTITY: ITEM NO. MODEL:
■ 13390

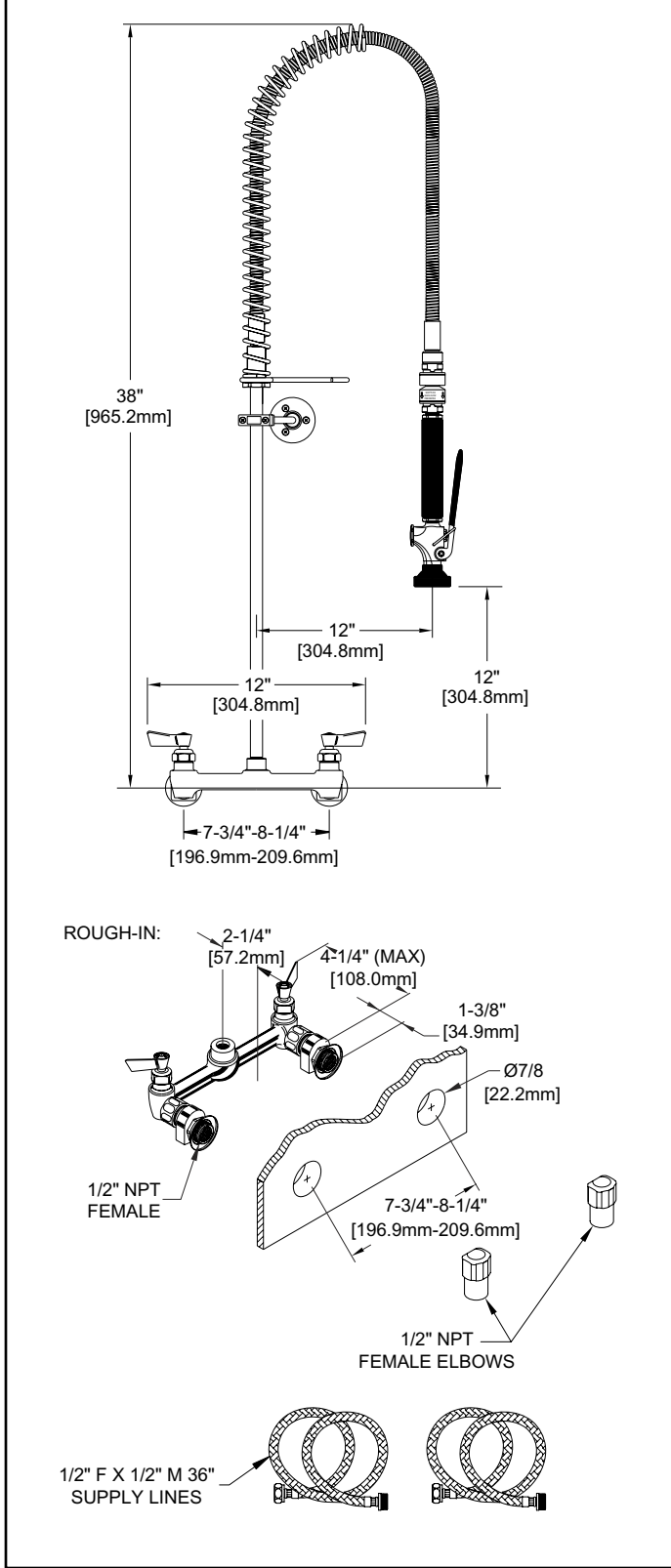

- OPTIONS OR MODIFICATIONS
- SUPPLY LINES (24" OR 36") CIRCLE LENGTH
 - ADD-ON FAUCET (6", 8", 10", 12", 14", 16") CIRCLE
 - IN-LINE DUAL CHECK VALVE
 - BRUSH
 - NIPPLES
 - ELBOWS
 - VANDAL RESISTANT KIT
 - HANDLES (CROSS OR WRIST) CIRCLE STYLE
 - OTHER _____

- FEATURES:
- CONTROL VALVE**
- * ECCENTRICS ADJUST FROM 7 3/4" TO 8 1/4"
 - * INTERNAL SPRING LOADED CHECK VALVES
 - * SWIVELLING SEAT DISKS
 - * HOT SIDE STEM - RIGHT HAND
 - * COLD SIDE STEM - LEFT HAND
 - * STAINLESS STEEL SEATS
 - * STAINLESS STEEL SEAT SCREWS
 - * STAINLESS STEEL HANDLE SCREWS
 - * 1/2" SLIP JOINT

- HOSE**
- * 36" LENGTH
 - * STAINLESS STEEL END FITTINGS
 - * STAINLESS STEEL EXTERNAL JACKET
 - * 3-PLY FIBER REINFORCED INTERNAL RUBBER HOSE

- ULTRA SPRAY VALVE**
- * 1.6 GPM @ 80 PSI ENERGY EFFICIENT NOZZLE
 - * BRONZE HANDLE - NOT PLASTIC - MEANS FULL "ON"
 - * FITS ALL BRANDS

- SYSTEM LIMITS**
- * TEMP: 40°F MIN. TO 140°F MAX.
 - * PRESSURE 200 PSI MAX. STATIC
 - * 2.65 GPM AT 80 PSI

- SHIPPING WEIGHT**
- * 15.0 LBS



FISHER MANUFACTURING COMPANY
TOLL FREE: 800-421-6162 - FAX: 800-832-8238
information@fisher-mfg.com - www.fisher-mfg.com

ANSI/A112.18.1M