

JOB NAME:

QUANTITY:

ITEM NO.:

PRODUCT NAME:

CLOSED REEL RINSE CEILING MOUNTED WITH UTILITY SPRAY VALVE

- 81345 SPECIAL CONFIGURATION (CHECK BASE MODEL AND OPTIONS)

MODEL:

- 32026

OPTIONS OR MODIFICATIONS:

- BRUSH
- OTHER UTILITY SPRAY VALVE

FEATURES:

REEL

- * CLOSED DESIGN
- * SELF-LOCKING
- * STAINLESS STEEL COVER
- * CEILING MOUNTED

HOSE

- * 30' LENGTH REEL HOSE
- * 3-PLY FIBER REINFORCED
- * 3/8" FEMALE NPT INLET
- * 18" LENGTH INLET HOSE
- * ADJUSTABLE BALL STOP

UTILITY SPRAY VALVE

- * NOZZLE THREADED INTO VALVE
- * 2.65 GPM AT 80 PSI
- * SHOWER SPRAY PATTERN
- * 45° ANGLED HEAD

SYSTEM LIMITS

- * TEMP: 40°F MIN. TO 140°F MAX. STATIC
- * PRESSURE 200 PSI MAX. STATIC

SHIPPING WEIGHT

- * 35.0 LBS

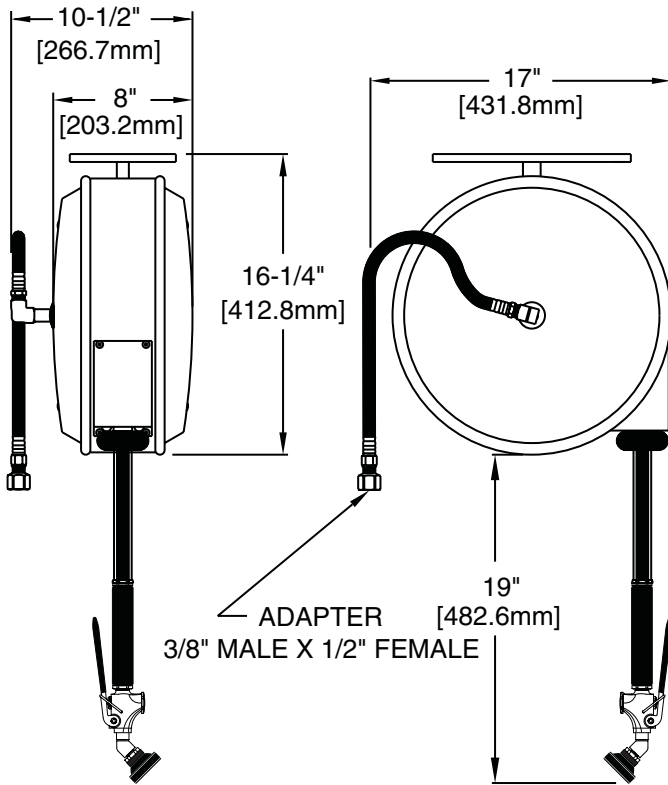

ROUGH-IN: SEE MOUNTING PLATE BELOW

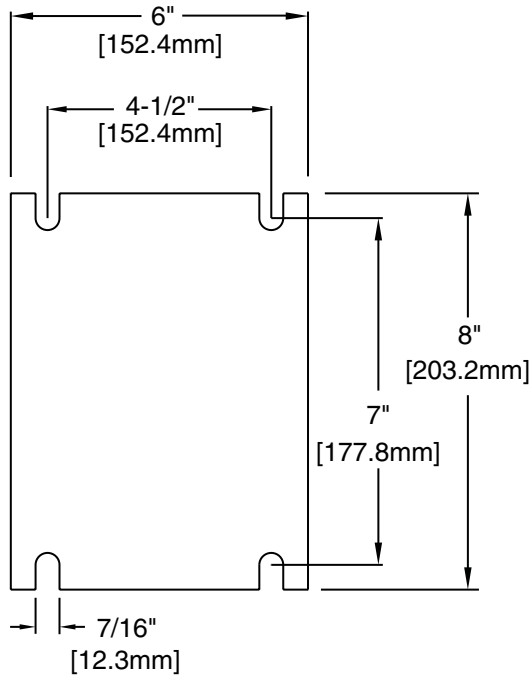

ANSI/A112.18.1M

FISHER MANUFACTURING COMPANY
 1900 SOUTH "O" STREET, TULARE, CALIFORNIA 93274
 MAILING ADDRESS: P.O. BOX 60, TULARE, CALIFORNIA 93275
 PHONE: (800) 421-6162 FAX: (800) 832-8238
 MADE IN U.S.A.