

Symphony™ ice and water dispenser

110 CM series countertop



SensorSAFE infrared dispense (optional)



Ice and water dispensers			
Ice storage capacity	Dispense	Voltage V/Hz	Item number
110 lb (50 kg)	lever	115/60	110CM-L
		220/60	C110CM-L
		230/50	E110CM-L
	SensorSAFE	115/60	110CM-S
		220/60	C110CM-S
		230/50	E110CM-S

Ice-only available (only in 115 V/60 Hz), add -SI or -LI
Example: 110CM-LI

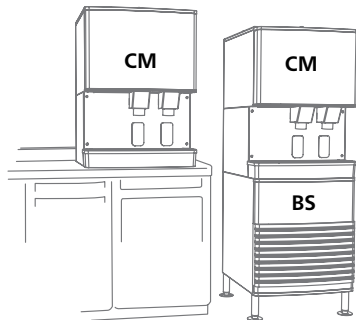

Features

110 lb (49.9 kg) ice storage capacity

Manual load dispenser reliably dispenses Follett® Chewblet® ice and most small cube ice up to 1.00" (2.54 cm) square

Durable, attractive dispenser

- stainless steel exterior with accent trim
- smooth contours for aesthetically appealing appearance
- corrosion-resistant poly drain pan and dispenser lid

Designed with sanitation in mind

- Agion® silver-based antimicrobial product protection of key ice and water contact components¹
- one-hand lever or SensorSAFE™ infrared ice dispense reduces the chance of cross-contamination
- SensorSAFE not recommended for use with clear containers or for applications in direct sunlight

Installation

- comes fully assembled
- three easy connections – electric, water and drain

Warranty

- 3 years parts and labor, 5 years compressor parts

Accessories

BS – Base stand (item# AF110BASESTD)

Chilled water option (item# AFH2OCHIL110)

Water filter kit (item# 00130229)

High capacity water filter kit (item# 00978957)

SafeCLEAN™ environmentally responsible ice machine cleaner (item# 00132001)

Nu-Calgon® IMS-II sanitizer, 16 oz bottle (item# 00979674)

Job

Item

Specification

Ice storage capacity	110 lb (49.9 kg)
W1 Width	24.50" (62.2 cm)
W2 Width, base stand accessory	26.25" (66.7 cm)
D1 Depth	28.25" (71.8 cm)
D2 Depth, drain pan	7.00" (17.78 cm)
D3 Depth, base stand accessory	29.00" (73.7 cm)
H1 Height	34.75" (88.3 cm)
H2 Height, base stand accessory	33.00" (83.8 cm)
H3 Dispense height clearance	7.62" (19.35 cm)
Service clearance	18.00" (45.7 cm) top for manual filling and cleaning
C1 115 V/60/1 electrical	4 amps, max. fuse 20 amps. 7' (2.1 m) cord, NEMA 5-20 90° hospital-grade plug.
C2 220 V/60/1 ("C" models) 230 V/50/1 ("E" models) electrical	1.5 amps. 7' (2.1 m) cord only.
C3 Water inlet	3/8" FPT internal connection – 1.5" (3.81 cm) knockout provided (230 V/50 model includes kit to connect to BSP water fittings)
C4 Drain	3/4" FPT
Utility connection location	back or bottom
Air temperature	50 - 100 F (10 - 38 C)
Water temperature	40 - 90 F (4 - 32 C)
Water pressure	10 - 70 psi (69 - 483 kpa)
Approximate ship weight	119 lb (54.0 kg)
Approximate ship weight, base stand accessory	140 lb (64 kg)

NOTE: For indoor use only

SHORT FORM SPECIFICATION: (Choose one) ___ Ice and water or ___ ice-only dispenser to be Follett® model 110CM manual load unit, (choose one) ___ with integral drain pan or ___ without integral drain pan for use with custom drain pan. Dispenser frame and cabinet to be stainless steel with plastic trim. Dispenser to hold up to 110 lb (49.9 kg) of ice depending on ice type used. Dispenser to have lightweight plastic top that allows full access to the ice storage area for easy manual loading. Storage area to be insulated with non-CFC, high density, foamed-in-place polyurethane. 7' (2.1 m) cord and NEMA 5-20 90° hospital-grade plug provided (220 V/230 V models, cord only). 115 V, 220 V and 230 V dispensers to be NSF listed. 115 V dispensers to be UL and cUL listed. 230 V dispensers to be CE listed.

Dimensional drawing

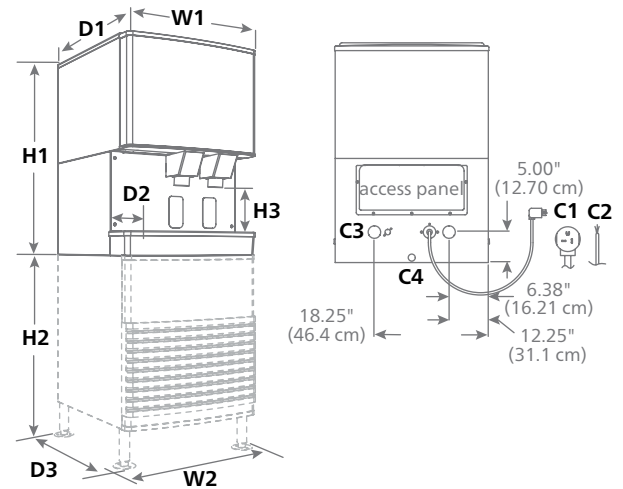

See dispenser detail sheet, form# 2075, for counter cut outs.

1 Disclaimer: Antimicrobial protection is limited to the treated components and does not treat water or ice.

Agion is a registered trademark of Sciessent LLC.

Calgon is a licensed tradename distributed by Nu-Calgon, in the United States.

Symphony, SensorSAFE and SafeCLEAN are trademarks of Follett Corporation.

Chewblet and Follett are registered trademarks of Follett Corporation, registered in the US.

Follett reserves the right to change specifications at any time without obligation. Certifications may vary depending on country of origin.

110 CM series countertop

Form #2095 08/13
© 2013 Follett Corporation



115 V
models only



230 V
models only

801 Church Lane | Easton, PA 18040, USA
1.800.523.9361 | 1.610.252.7301 | follettice.com

FOLLETT[®]
Innovative solutions, inspired by ice