



Ice Pro™ DB650 Series

automatic ice bagging and dispensing system

Features

Fast, labor saving ice dispense

- Store up to 650 lb (295 kg) of ice
- eliminates the need to shovel or scoop ice from bin
- fill up to 8 x 8 lb (3.6 kg) bags a minute
- automatic agitation cycle prevents ice from forming bridges
- push-button actuation automatically dispenses ice at a rate of up to 100lb/min

Fresher ice

- first ice in is first ice out

Ice Compatibility

- dispenses most cube ice up to 1.00" (2.54 cm) and customer preferred Chewblet® ice into most carts and containers

Durable, user-friendly construction

- bag stand adjusts to fit up to 20 lb (9 kg) ice bags and can be used to fill containers such as Totes™ ice carrier or small ice coolers
- bag stand removes to fit carts or coolers up to 28.00" (71.1 cm) high
- easy-to-use controls with push button or time dispense
- bag opener blows bags open automatically
- corrosion-resistant poly bin
- dispensing components are easily removed for cleaning
- removable, lockable clear window prevents unauthorized access to ice and provides full access for cleaning
- access from front and side for maintenance
- bag holder pins quickly adjust for use with wire-wicket ice bags with 5.00" (12.7 cm) to 10.00" (25.4 cm) holes on center

Includes:

- 125 x 8 lb (3.6 kg) ice bags and reorder information
- bag stand
- cleaning brush and bracket

Accessories

- 8 lb (3.6 kg) ice bags (item# 00116434)
- 20 lb (9 kg) ice bags (item# 00138370)
- Bostitch P-7 C-ring plier for closing bags (item# 00137711)
- Staples, aluminum blunt-end C-rings for Bostitch P-7 plier (item# 00137729)
- Foot pedal (item# 00932517)
- Jug and cooler filling kit (item # 00979013)

Job

Item

Ice dispensing system		
Ice storage capacity	Voltage	Item number
650 lb (295 kg)	220 V/60/1	DB650SA
	230 V/50/1	EDB650SA

Specification

Maximum bin capacity ¹	650 lb (295 kg)
Cubic capacity	20 cu ft (0.57 cu m)
W1 Width	33.75" (85.7 cm)
W2 Width, bin top	30.38" (77.1 cm)
D1 Depth, without bag stand	46.75" (118.7 cm)
D2 Depth, bin top	31.25" (79.4 cm)
D3 Depth, with bag stand	48.25" (122.6 cm)
H1 Height ²	66.50" (168.9 cm) adjustable
W3 Drip tray width	16.75" (42.5 cm)
D4 Drip tray depth	10.12" (25.7 cm)
L1 Dispense clearance	28.00" (71.1 cm)
L2 Bag stand dispense clearance	26.00" (66.0 cm)
Installation clearance	34.25" (87.0 cm) wide door access
Service clearance	12.00" (30.5 cm) right side
C1 Electrical ³	2.5 amps, max. fuse 15 amps. 7.00' (2.1 m) cord with NEMA 6-15 plug.
220 V/60/1	
C2 Electrical ³	2.4 amps, max. fuse 15 amps. Cord only. Wire in accordance with all local codes.
230 - 240 V/50/1	
L3 Drain ⁴	1.00" FPT
Dispense rate	up to 75 lb (34 kg) per minute
Ice compatibility	non-flake up to 1.00" (2.54 cm) square
Air temperature	60 - 90 F (16 - 32 C)
Shipping weight	460 lb (205 kg)

NOTES: For indoor use only

Short form specification:

Automatic ice storage and dispensing system to be Follett (choose one) _____ 220 V DB650SA or _____ 230 - 240 V EDB650SA with elevated bin and base. Bin to hold up to 650 lb (295 kg) of ice. Dispense rate to be approximately 75 lb (34 kg)/min. Two position ice discharge chute with selector lever allows filling of bags or other containers. Lockable clear inspection window shall have interlock switch to prevent operation if window is removed. Hopper to be constructed of double wall rotationally molded polyethylene insulated with non-CFC polyurethane foam. Heavy-duty agitation system includes two stainless steel agitators and motors. Dispense auger to be rotationally molded plastic, driven by 1/4 HP motor. Activation of the dispensing function shall be controlled by push-button. Dispenser shall be equipped with holding pins for bags, time dispense, and blower function for automatically opening bags. Dispenser to be NSF, UL and cUL listed.

Notes:

- ¹ Computed on cubic volume of bin. Does not reflect voids that can occur due to pyramiding.
- ² Special top required for ice machines less than 30.00" (76.2 cm) wide and Follett Horizon™ ice machines. Add 1.75" (4.44 cm) to height.
- ³ C1, C2 – within 7' (2.1 m) from right rear corner
- ⁴ Follett recommends installation of a floor drain with grate with all ice storage bins.

Local food regulations vary. Please check with your local authorities for requirements for packaged ice.

Warranty:

Follett Corporation warrants to the original purchaser that all parts shall be free from defects in material and workmanship under normal use and service for a period of 2 years from the date of installation. Date of installation shall not exceed 90 days from date of shipment. Parts and labor for repair within this 2 year period are covered under this warranty. Removal of ice machine to service bin and any labor costs incurred are expressly excluded from this warranty.

Dimensional drawing

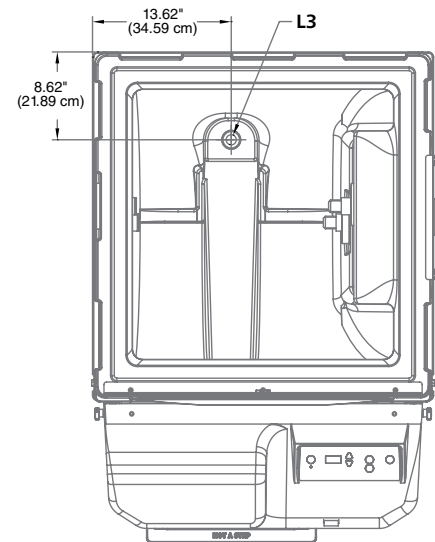
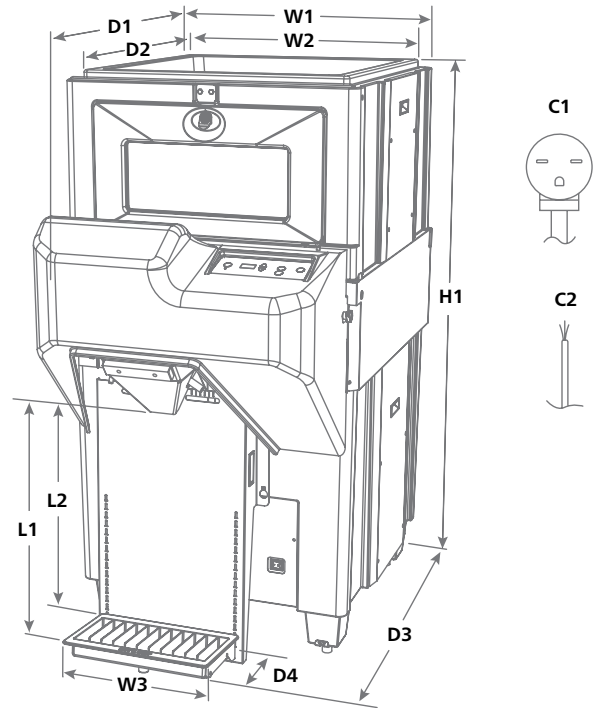

Horizon, Ice Pro and Totes are trademarks of Follett Corporation. Chewblet and Follett are registered trademarks of Follett Corporation, registered in the US. Follett reserves the right to change specifications at any time without obligation. Certifications may vary depending on country of origin.