

-20 C (-4 F) undercounter freezers

FZR
Series

FZR5 – Freestanding or built-in below standard 36" (915 mm) high counters, 4.2 cu ft (119 L) useable storage

FZR4-ADA – Freestanding or built-in below 34" (864 mm) high ADA-compatible counters, 3.5 cu ft (99 L) useable storage

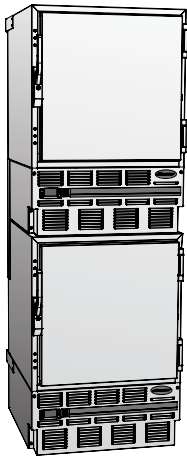

(2) freezers shown with stacking kit accessory (item# 00926618)

Medical-grade -20 C (-4 F) undercounter, freestanding and stackable freezers with external temperature display. Provide secure, stable-temperature storage for patient-floor, lab, pharmacy and mother's milk applications. Stainless steel interior/exterior. Automatic defrost.

Delivers consistent temperatures and product security

- Factory set at -25 C
- Set point adjustable -30 C (-22 F) to -15 C (5 F)
- Heavy-duty 1/3 HP compressor, forced-air cooling, digital microprocessor controller and thermal expansion valve (TXV) provide stable temperature, quick temperature pull down and rapid recovery following door openings and defrost cycles
- Temperature-terminated automatic defrost ensures product integrity during defrost
- Digital microprocessor controller incorporates defrost control, eliminating need for external, mechanical timer
- Positive, locking door latch and magnetic gasket provides secure closure and product security
- Supports Joint Commission, CDC and VFC standards for vaccine and medication storage

Saves staff time, provides exceptional flexibility

- External digital temperature display in user-selectable °C or °F provides easy logging without opening door
- Automatic defrost cycle frees staff from manual defrost
- Adjustable temperature range for nourishment applications
- Field-reversible stainless door provides location flexibility
- Dished floor contains spills, allows easy clean-up
- Two adjustable epoxy-coated shelves adjust for varied product
- Compatible with all major automatic medication dispensing systems

Easy installation and outstanding service access

- Front-breathing design requires no top, back or side clearances
- Inset door swing allows positioning next to other equipment without interference
- Nylon-padded leveling feet protect floors
- Automatic condensate evaporation eliminates drain
- Front panel removes easily to access condenser, controller and condensate pan
- Removable evaporator cover allows complete access to evaporator, TXV, fan, heater and heater safety switch
- Rear slide-out condensing unit provides complete access

Industry's best warranty

- 2 yr parts and labor on entire freezer
- 5 yr parts on compressor
- Toll free factory technical assistance

Accessories

- Temperature alarm with immersible probe and °C/°F display (item #00112185)
- Additional shelf (2 shelves standard) (item# 00159699)
- Pyxis® compatible door bracket (item# 00114702)
- Omnicell® compatible door bracket (item# 00158014)
- Stacking kit (item# 00926618)
- Pedestal stand (item# 00931154)

*Pyxis® is a registered trademark of Cardinal Health in the United States and other countries.
*Omniceil® is a registered trademark of Omnicell, Inc. in the United States.

JOB: _____

ITEM: _____

**Front View
FZR5**

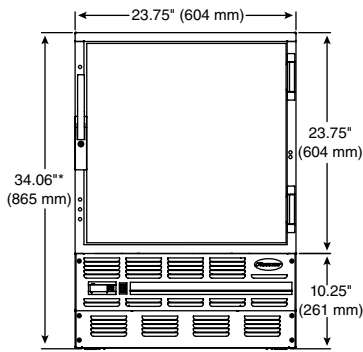

* Height includes leveling legs

**Side View
FZR5**

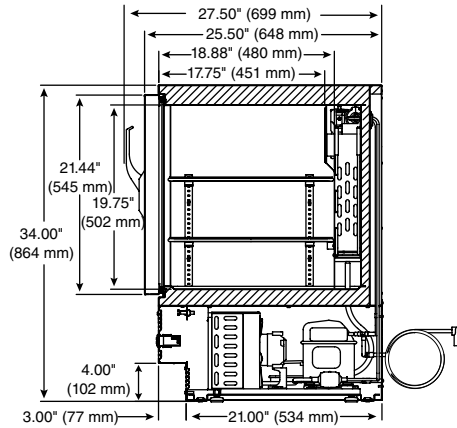

**Top View
all models**

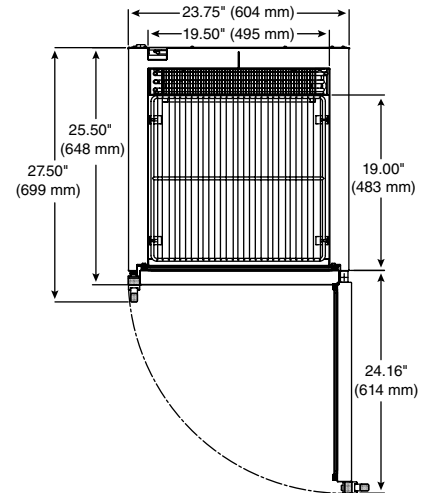

**Front View
FZR4-ADA**

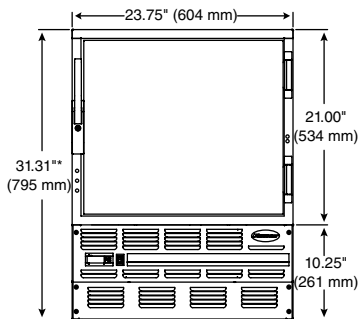

* Height includes leveling legs

**Side View
FZR4-ADA**

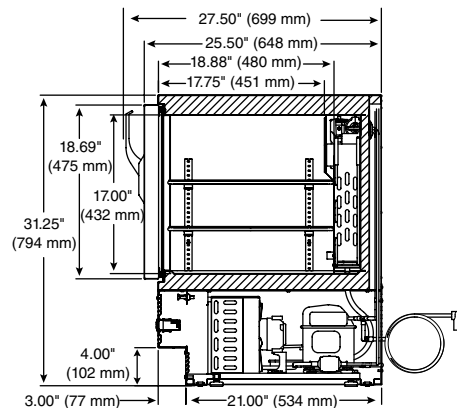

**Back View
all models**

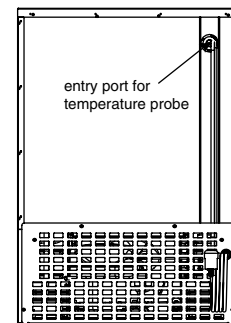

Refrigerant R404A, 7.9 oz

Max. heat rejection 890 BTU/hr

Electrical

115 V, 60 Hz, 1 ph, 8.0 amps, max. fuse 15 amps. Hospital-grade cord and plug provided.

Approximate shipping weight 175 lbs (79 kg)

Specifications Undercounter freezer to be Follett® model (choose one) _____ FZR5 34.06" (865 mm) high for use in standard 36" (915 mm) high counters and to have 4.2 cu ft (119 L) capacity or _____ FZR4-ADA 31.31" (795 mm) high for use in 34" (864 mm) high ADA-compatible counters and to have 3.5 cu ft (99 L) capacity. Environmentally friendly R404A refrigeration system to include heavy-duty 1/3 HP compressor, blower, blower coil and automatic evaporative forced air cooling with electric temperature-terminated defrost. Freezer to be equipped with external temperature display (factory default °C, controller programming key included for °F) and solid-state controller to maintain uniform cabinet temperatures. Controller to have adjustable set point to meet varied temperature needs for different applications. Freezer door to be field-reversible and equipped with replaceable gasket and chrome-plated handle with cylinder lock. Freezer interior and exterior to be stainless steel. Two epoxy-coated wire shelves adjust in 1/2" (13 mm) increments. Storage area to be insulated with high-density, non-CFC foam polyurethane. Hospital-grade cord and plug provided. Freezer to be UL and cUL listed.

**Handle Detail
all models**

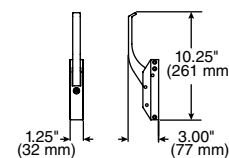

**Plug Detail
all models
NEMA 5-15**

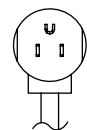

Follett is a registered trademark of Follett Corporation, registered in the US. Follett reserves the right to change specifications at any time without obligation. Certifications may vary depending on country of origin.