

# Options and accessories for REF and FZR series undercounter refrigerators and freezers

## Keypad locking system



Factory-installed keypad lock provides more product security and ease of use. Multiple user codes provide greater control over access. Available factory-installed for new REF orders; as a retrofit kit for existing REFs. Not available for FZR series.

### Increased security

- Door opens only when authorized code is entered and relocks when closed
- Each keypad provides one master code and up to eight user codes
- Lock-out feature prevents opening after repeated random code entry
- Secure and reliable motor-driven bolt operation

### Ease of use

- No turning of keypad to unlock or relock door
- Easy addition and deletion of user codes
- Two 9-volt alkaline batteries provide approximately 8000 openings
- Low battery alert signals for battery replacement
- Batteries accessed from front without tools
- All codes retained during battery replacement

| Model         | Item# for REF with Factory-Installed Keypad | Item# for Retrofit Kit for Existing REF |
|---------------|---|---|
| REF5          | REF5-KP_ _ _ _                              | 00170688                                |
| REF4-ADA      | REF4-KP_ _ _ _                              | 00170688                                |
| REF5-BB       | REF5-KP_ _ CR                               | 00170688                                |
| FZR5/FZR4-ADA | NA  | NA                                      |
| FZR5-PL       | NA  | NA                                      |

## Temperature alarm



Solid-state temperature alarm provides hi-low audible and visual alarms, visual verification of product temperature, and highest-lowest temperature log.

### Protection for medications and patient supplies

- Audible and/or visual alarm with user-selectable high and low set points
- Digital product temperature display in °F or °C
- NO/NC dry contacts can be wired to central alarm system
- 9-volt backup battery (included) ensures protection during power outages
- Supports Joint Commission standards for medication storage
- Records highest and lowest temperature since last reset
- Complete with product simulation bottle and bottle bracket

### Easy installation

- Compact module (3.125"W x 1.875"D x 4.75"H (80 mm x 48 mm x 121 mm)) mounts in desired location with screws (not provided)
- 8' (2.4 m) probe wire increases location flexibility
- Includes 115 V power supply with 6' (1.8 m) cord

| Model    | Item#    |
|----------|----------|
| REF5     | 00112185 |
| REF4-ADA |          |
| REF5-BB  | NA †     |
| FZR5     | 00112185 |
| FZR4-ADA |          |
| FZR5-PL  | NA †     |

† REF5-BB and FZR5-PL include alarm in standard temperature surveillance module (page 2).

# Options and accessories for REF and FZR series undercounter refrigerators and freezers

## Temperature surveillance module



| Model    | Item#                |
|----------|----------------------|
| REF5     | 00168674             |
| REF4-ADA |                      |
| REF5-BB  | included as standard |
| FZR5     | 00168674             |
| FZR4-ADA |                      |
| FZR5-PL  | included as standard |

All-in-one temperature surveillance module provides extra security for critical product storage.

### Monitor product temperatures with confidence

- Audible and/or visual alarm with user-selectable high and low setpoints
- Compact chart recorder with easy-to-read 6" (153 mm) 7-day chart
- Digital product temperature display
- LED power status indicator
- Remote contacts for connecting to central alarm system
- 9-volt backup battery ensures protection during power outages
- Includes product simulating bottle and box of (60) 7-day charts (-50 to 50)

### Easy installation

- 15' (4.6 m) probe wire with immersible stainless steel tip
- 6' (1.8 m) power cord and AC adapter
- Compact (7.56" x 7.56" x 3.25" (192 mm x 192 mm x 83 mm)), surface or wall mount ready

### Replacement charts and pens

- Replacement charts (box of 60, 7-day, -50 to 50) (item# 00162099)
- Replacement pens (box of 6, red) (item# 00162081)

## Medication system compatibility brackets

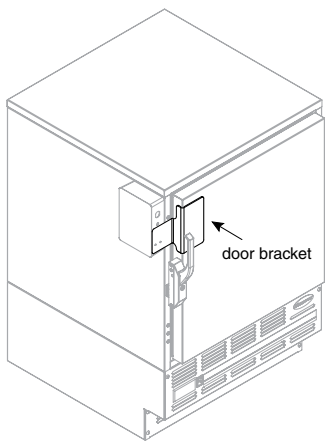

Door brackets allow Follett® refrigerators and freezers to be used with Pyxis\* and Omnicell\* automated medication dispensing systems.

- Bracket installation must be performed by authorized Pyxis or Omnicell\* installer
- Follett brackets are not required for MedSelect\* and AcuDose-Rx\* compatibility. Appropriate brackets are available thru MedSelect and AcuDose-Rx supplier.
- Undercounter installations require side clearances for lock boxes. Check with your medication dispensing system representative.

| Model    | Pyxis – Item# | Omnice ll – Item# |
|----------|---------------|-------------------|
| REF5     | 00114702      | 00158014          |
| REF4-ADA |               |                   |
| REF5-BB  | NA            | NA                |
| FZR5     | 00114702      | 00158014          |
| FZR4-ADA |               |                   |
| FZR5-PL  | NA            | NA                |

\* Pyxis is a registered trademark of Cardinal Health in the United States and other countries.

\* Omnicell is a registered trademark of Omnicell, Inc. in the United States.

\* MedSelect is a registered trademark of the AmerisourceBergen Technology Group.

\* AcuDose-Rx is a registered trademark of McKesson.

# Options and accessories for REF and FZR series undercounter refrigerators and freezers

## Additional shelves



item# 00131748 shown

### REF series cut out shelf

- Epoxy-coated wire shelf has cut-out to fit around evaporator drain
- Provides additional 2.4 sq. ft (0.22 sq m) of shelf storage space
- Allows storage to each side and in front of evaporator housing

### FZR series full size shelf

- Epoxy-coated wire shelf
- Provides additional 2.3 sq. ft (0.21 sq m) of shelf storage space

| Model    | Item #   |
|----------|----------|
| REF5     | 00131748 |
| REF4-ADA |          |
| REF5-BB  | NA       |
| FZR5     | 00159699 |
| FZR4-ADA |          |
| FZR5-PL  | NA       |

## Stacking kit

Must be ordered with equipment.

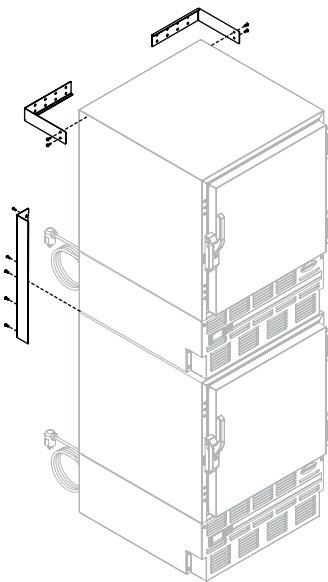

Refrigerator and / or freezer not included.

Brackets and wall anchor hardware maximize floor space by allowing any combination of Follett undercounter refrigerators and freezers to be stacked. Order item# 00926618.

### Kit includes

- Stainless steel back brackets to secure units together
- Stainless wall brackets to anchor stacked configuration to wall
- Installation instructions

# Options and accessories for REF and FZR series undercounter refrigerators and freezers

## Pedestal base

Must be ordered with equipment.

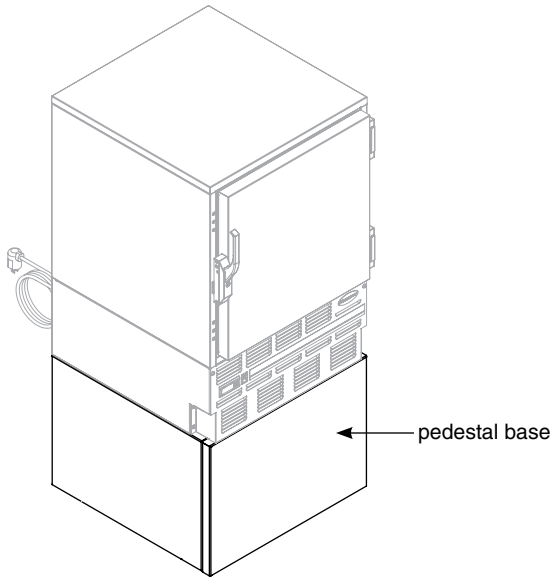

Refrigerator and / or freezer not included.

17" (432 mm) tall stainless steel base elevates any Follett undercounter refrigerator or freezer height allowing easy access. Order item# 00931154.

- Same footprint as REF or FZR – 23.75" wide x 24" deep (603 mm x 610 mm)
- All stainless construction
- Leveling feet with plastic glides
- Ships in separate carton
- Shipping weight 63 lbs (29 kg)

## Controller programming keys



Controller keys allow facilities to quickly change controller temperature displays from factory settings to different scales (°F or °C) or to upload customized settings to multiple refrigerators or freezers.

- No limit to number of times keys may be used or reprogrammed
- All keys can be overridden by downloading any temperature setting and scale configuration from a refrigerator or freezer to the key
- All keys plug into 5 pin connection in controller back
- Note – FZR, REF, REF-BB, and FZR5-PL keys are not interchangeable
- Contact factory for key specific to your model and application

Follett is a registered trademark of Follett Corporation, registered in the US.  
Follett reserves the right to change specifications at any time without obligation. Certifications may vary depending on country of origin.