

DRAUGHT BEER FRIDGE



Model ZPJ-170

FEATURES:

- Easy to use draft dispenser.
- Easy installation.
- Move the unit freely with the adjustable caster wheels.
- Removable drip tray.

INCLUDED:

- Keg coupler
- Glass marble
- Rubber choke
- CO2 regulator
- Beer tower tap / beer hose assembly
- Beer tower washer
- High pressure washer
- Air hose
- Drip pan top
- Keg base board
- Beer Tower hole cover
- CO2 tank valve
- Guard rail
- Beer tap wrench

NEMA
5 - 15
125 VAC / 15 AMP



SPECIFICATIONS

Model	ZPJ-170
Description	Beer keg fridge (6.0cu.ft)
Capacity	170L / 6.0 Cubic Feet
Rated Current	1.9A
Rated Frequency	60Hz
Rated Voltage	115V
Weight	88 lbs.
Packaging Weight	94 lbs.
Dimensions (DWH)	21.25" x 25.25" x 47.25"
Packaging Dimensions	27.75" x 23" x 35"
Item #	23829



DIMENSIONS

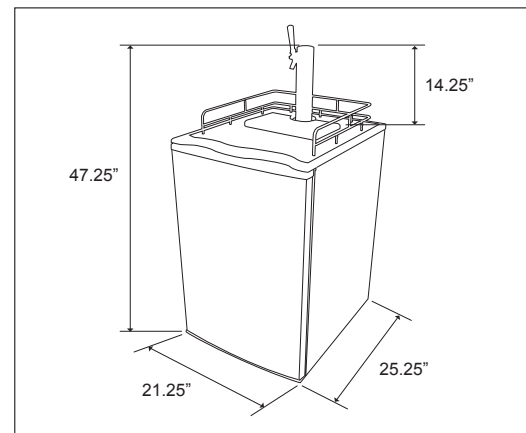

Mississauga, Ontario, Canada

Tel: (905) 828-0234 Toll-Free: 1-800-465-0234 Fax: (905) 607-0234 Email: sales@omcan.com

Niagara Falls, New York, USA

www.omcan.com