

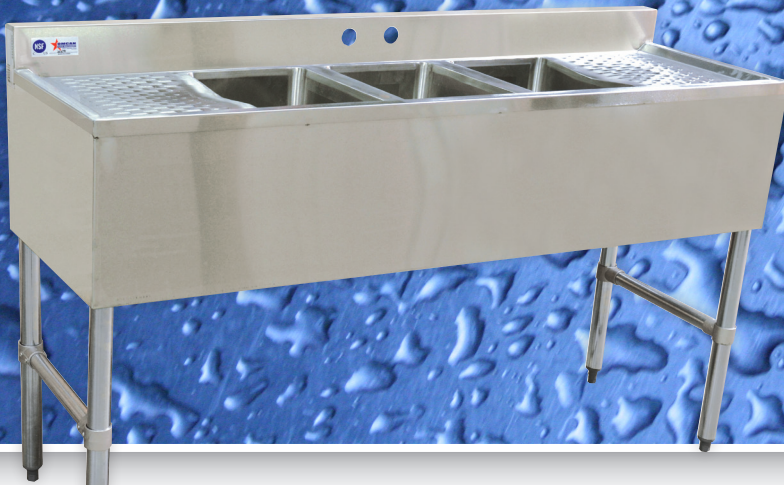

UNDER BAR SINK

**UNDER BAR
SINK**



- Comes with corner drain guards
- Three compartments
- Two drain boards
- Stainless Steel: 304
- Gauge: 18
- Faucet holes are 8" on center.
- Shipped with legs removed.



Item	Item Description	Overall Dimensions (DWH)	Weight (lbs)
25274	Under bar sink with 3 compartments (10" x 14" x 10") with two drain boards.	60" x 18 3/4" x 37"	77

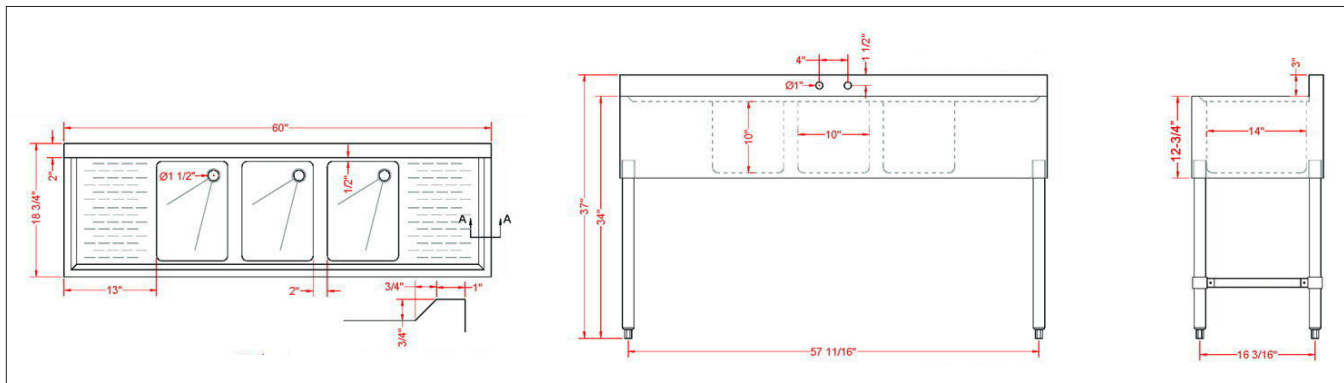

Mississauga, Ontario, Canada

Niagara Falls, New York, USA

Tel: (905) 828-0234 Toll-Free: 1-800-465-0234 Fax: (905) 607-0234 Email: sales@omcan.com

www.omcan.com