



FOOD EQUIPMENT

CENTER OF ALL YOUR FOOD SERVICE NEEDS

COUNTERTOP SINGLE AND DOUBLE BULB HEAT LAMP

Item #:39602/ 39601

Model: FW-CN-0736/ FW-CN-0936



- Great for fast food restaurants, snack bars, catering, concession stands and buffets
- Perfect for keeping potato wedges, french fries, chicken or onion rings warm and ready to serve
- CE certified



Authorized Dealer

Detail Shots



275 Watt
Infrared Bulbs



Ventilated Reflectors



Comes with a drip tray



One switch per lamp



110-120V
Electrical connector

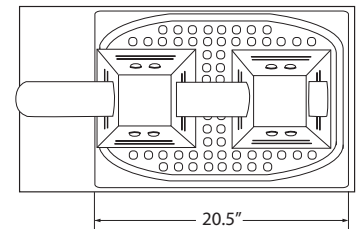
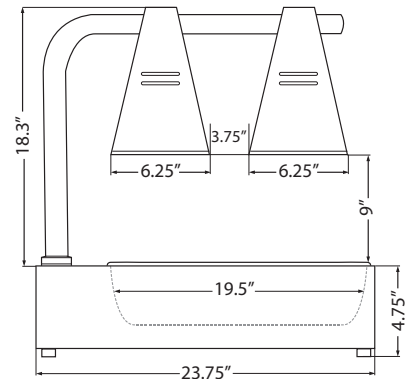
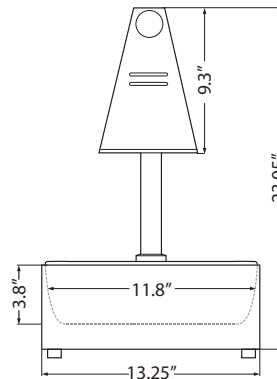
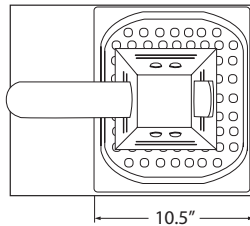
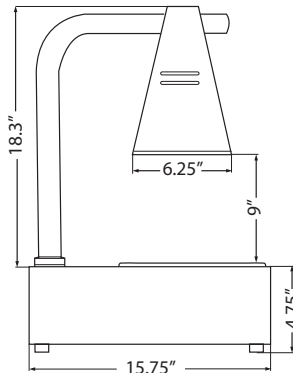
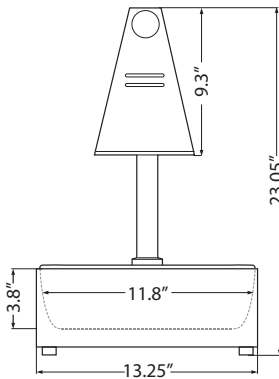

COUNTERTOP SINGLE BULB HEAT LAMP

| | |
|----------------------|------------------------------------------------|
| ITEM NUMBER | 39602 |
| MODEL | FW-CN-0736 |
| INPUT POWER | 0.275 kW |
| ELECTRICAL | 110V / 60Hz |
| NET WEIGHT | 6.6 lbs / 3 kg. |
| PACKAGING WEIGHT | 8.4 lbs . / 3.8 kg. |
| DIMENSIONS (DWH) | 15.7" x 13.25" x 23.05" 40 x 33.7 x 58.5 cm |
| PACKAGING DIMENSIONS | 15.6" x 17.7" x 24" 39.6 x 45 x 61 cm |

COUNTERTOP DOUBLE BULB HEAT LAMP

| | |
|----------------------|---------------------------------------------------|
| ITEM NUMBER | 39601 |
| MODEL | FW- CN-0936 |
| INPUT POWER | 0.275 kW |
| ELECTRICAL | 110V / 60Hz |
| NET WEIGHT | 12 lbs. / 5.5 kg. |
| PACKAGING WEIGHT | 14 lbs. / 6.4 kg. |
| DIMENSIONS (DWH) | 23.75" x 13.25" x 23.05" 60.3 x 33.7 x 58.5 cm |
| PACKAGING DIMENSIONS | 15.6" x 25.6" x 24" 39.6 x 65 x 61 cm |

OMCAN INC.

Telephone: 1-800-465-0234
 Fax: (905) 607-0234
 E-mail: sales@omcan.com
 Website: www.omcan.com



Follow us to keep up to date with the latest news and offers

