

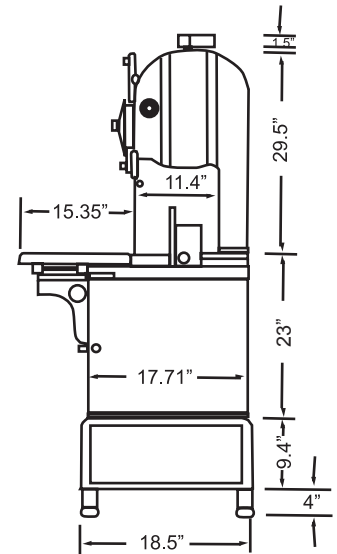

## MODEL B34

Fabricated in steel with electrostatic oven paint, complete with an aluminum head. Its stainless steel table has a four-wheel base that slides on rails. Equipped with adjustable legs. Easy to disassemble for quick cleaning and maintenance.

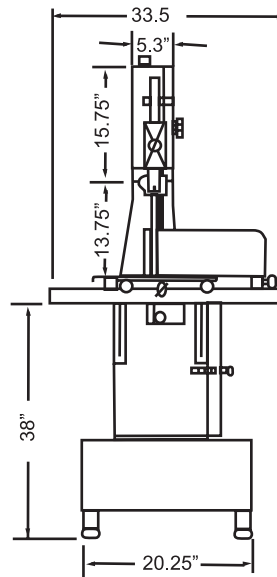

### SPECIFICATIONS

<b>Model</b>	<b>B34</b>
<b>Blade Length</b>	98"
<b>Cutting Capacity (H*W)</b>	12" x 10.5"
<b>HP</b>	2 HP
<b>Electrical</b>	220V/60/1

<b>Weight</b>	346 lbs.
<b>Packaging Weight</b>	400 lbs.
<b>Packaging Dimensions</b>	36" x 40" x 72"
<b>Item #</b>	10271



Mississauga, Ontario, Canada

Niagara Falls, New York, USA

Tel: (905) 828-0234 Toll-Free: 1-800-465-0234 Fax: (905) 607-0234 Email: sales@omcan.com

[www.omcan.com](http://www.omcan.com)