

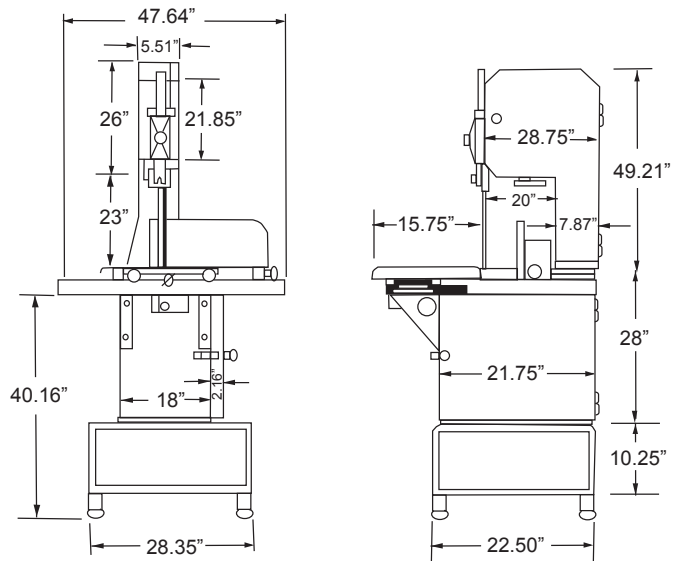

MODEL B40

Fabricated in steel with electrostatic oven paint, complete with an aluminum head. Its stainless steel table has a four-wheel base that slides on rails. Equipped with adjustable legs Easy to disassemble for quick cleaning and maintenance.



SPECIFICATIONS

Model	B40	Electrical	220V/60/1
HP	3 HP	Weight	374 lbs.
Cutting Capacity	15" x 18"	Packaging Weight	415 lbs.
Blade Saw Dimensions	0.78" x 12.60"	Packaging Dimensions	40" x 54" x 96"
Blade Length	126"	Item #	10272



Mississauga, Ontario, Canada

Niagara Falls, New York, USA

Tel: (905) 828-0234 Toll-Free: 1-800-465-0234 Fax: (905) 607-0234 Email: sales@omcan.com

www.omcan.com