

PATIO HEATER

Outdoor Patio Heater

The Model BFH-SS is an attractive solution to heating your outdoor venues.

FEATURES:

- Stainless Steel Body.
- Elegant Design.
- Alloy Frame.
- Quartz Tube.
- Aluminum Reflector.
- Stainless Steel Wire Mesh.
- Flame Height Adjustment Knob.
- Push Button Ignition.
- Can Accommodate a 20 or 30lb propane tank (not included).
- Made in China.

Specifications

Model	BFH-SS
Description	Outdoor Patio Heater with Quartz Tube
Fuel	Propane or Butane
Consumption	590g / hr.
Quartz Tube Dimensions	4"0 x 49.25"
Dimensions (DWH)	20.75" x 20.75" x 90"
Packaging Dimensions	6.5" x 30" x 55.5"
Weight	50.75 lbs. / 23 kg.
Packaging Weight	57.25 lbs. / 26 kg.
Item #	31879

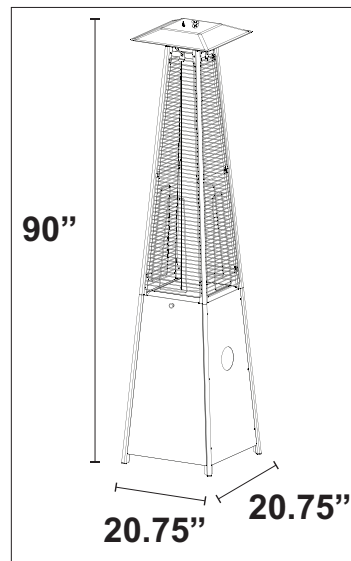

Standard 20lb tank not included



Shipped knock down.
Assembly required.

Mississauga, Ontario, Canada

Niagara Falls, New York, USA

Tel: (905) 828-0234 Toll-Free: 1-800-465-0234 Fax: (905) 607-0234 Email: sales@omcan.com

www.omcan.com