



**C 33 F/N Meat Slicer**

This slicer is NSF8-2010 approved and meets the highest levels of hygiene and safety. The two independent motors and gear drive system ensure precise and effortless slicing.

- GEAR driven transmission.
- ON/OFF one touch s/s switches with LED flush with slicer casting.
- Removable parts for cleaning, blade cover, product-holder plate, aluminum meat grip, stainless steel slice deflector.
- Fast - no tools removable meat grip.
- Blade with NARROW BAND of chromium - plated hardened steel.
- 45° inclined blade.
- Turning aside and REMOVABLE sharpener.
- Dual action sharpener.
- Fixed ring guard.
- Interlock on gauge plate on zero position.
- Big size product - holder plate.
- Readily removable transparent Plexiglas Protection at product - holder plate.
- High reliability of all elements.
- New design with large spaces.



<b>Item</b>	38917
<b>Model</b>	C 33 F/N
<b>Blade</b>	13" / 330 mm
<b>Power</b>	350 Watts / 0.47 HP
<b>Slicing Capacity</b>	□ 10.6" x 6.7" ○ 9.45"
<b>Cut Thickness</b>	0 - 0.55" / 0 -14 mm
<b>Drive</b>	Gear
<b>IP</b>	65
<b>RPM</b>	240
<b>Voltage</b>	120V / 60Hz / 1PH
<b>Weight</b>	43 kg. / 94.8 lbs.
<b>Packaging Weight</b>	50 kg. / 110 lbs.
<b>Packaging Dimensions</b>	32.7" x 28" x 26.7"

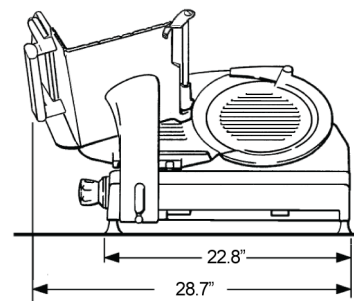
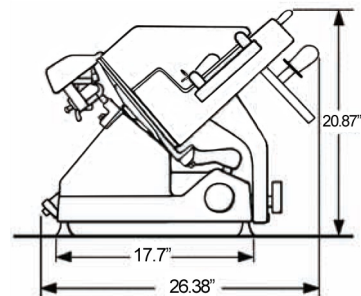

Mississauga, Ontario, Canada

Niagara Falls, New York, USA

Tel: (905) 828-0234 Toll-Free: 1-800-465-0234 Fax: (905) 607-0234 Email: sales@omcan.com

[www.omcan.com](http://www.omcan.com)