

AUTOMATIC MEAT SLICER



C X Matic 33 F/N Meat Slicer

This slicer is NSF8-2010 approved and meets the highest levels of hygiene and safety. The two independent motors and gear drive system ensure precise and effortless slicing.

- Automatic slicer.
- Adjustable carriage stroke and consequent n° of cuts.
- GEAR driven transmission.
- Two separate motors – one for the blade – one for the carriage, results in no reduction of power in automatic mode.
- Removable parts for cleaning: blade cover, product-holder plate, aluminum meat grip, stainless steel slice deflector.
- Fast - no tools removable meat grip.
- Blade with narrow band of chromium plated hardened steel for precision slicing.
- 45° inclined blade.
- Rotating and removable, dual-action sharpener.
- Fixed ring guard.
- Interlock on gauge plate on zero position.
- Big size product - holder plate.
- Readily removable transparent Plexiglas Protection at product - holder plate.
- High reliability of all elements.
- Features lifting arm and is designed for easy access and cleaning.
- Fence included.
- Variable stroke adjustment for quick slicing of smaller products.

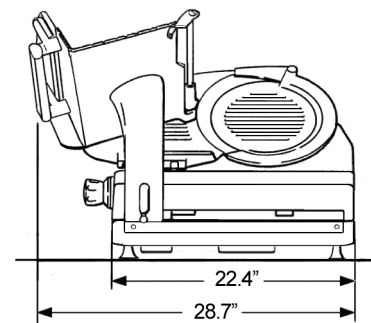
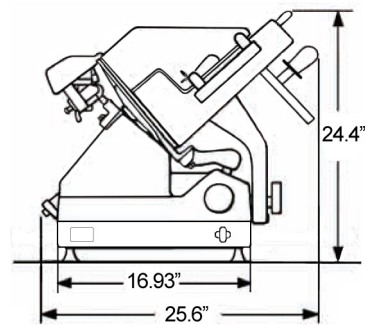

| | |
|-----------------------------|------------------------|
| Item | 39477 |
| Model | CX MATIC 33F/N |
| Blade | 13" / 330 mm |
| Power | 450 Watts / 0.60 HP |
| Slicing Capacity | □ 10.2" x 6.7" ○ 9.25" |
| Cut Thickness | 0 - 0.55" / 0 -14 mm |
| Drive | Gear |
| IP | 55 |
| RPM | 240 |
| Voltage | 120V / 60Hz / 1PH |
| Weight | 59 kg. / 130 lbs. |
| Packaging Weight | 74 kg. / 163 lbs. |
| Packaging Dimensions | 36.2" x 33.8" x 32.7" |

Mississauga, Ontario, Canada

Niagara Falls, New York, USA

Tel: (905) 828-0234 Toll-Free: 1-800-465-0234 Fax: (905) 607-0234 Email: sales@omcan.com

www.omcan.com