

# MEAT GRINDER

## Model SM-G50

This electric meat grinder is designed for portability and convenience. Ideal for home use.

- # 10 heavy-duty aluminum grinder head
- Equipped with a reverse switch
- Durable die-cast meat tray.
- 3 Stainless steel machine plates 3/16" / 5mm (fine), 5/16" / 8mm (medium), 3/8" / 10mm (coarse)
- Comes with a meat pusher and sausage stuffing tubes
- Built-in circuit breaker to prevent overload.



Model SM-G50

### SPECIFICATIONS

Model	SM-G50
Horsepower	0.50 HP
Throat Size	2"
Amps	3
Plate Size	5mm, 8mm, 10mm
Spout Size	12mm, 17mm, 20mm
Electrical	110V/60/1
Ship Weight	13.6 lbs.
Dimensions (LWH)	16.5" x 8" x 13.5"

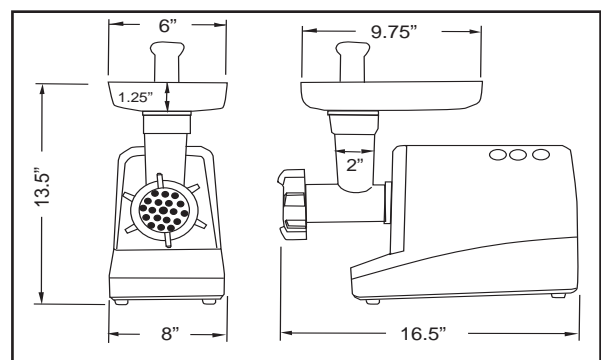

OMCAN INC.  
Food Machinery of America Inc.

Email: [sales@omcan.com](mailto:sales@omcan.com) ♦ Phone: 1.800.465.0234 or 905.828.0234 ♦ Fax: 905.607.0234