



PROJECT:	MODEL:	QUANTITY:	ITEM NO:

MOBILE BARS & BACK-UP

For Conventional Beverage Service Using Cans and Bottles

WEATHER-ALL "SCB SERIES"



WEATHER-ALL Series

ALL STAINLESS STEEL



SCB-66



SCB-66

SIC-222
Ice Storage Cart



made to serve you better

These rugged bars are constructed from all stainless steel for year-round indoor/outdoor usage.



TM

Constructed entirely of stainless steel, these attractive and functional bars are tough enough to be used outside year-round, and beautiful enough to grace the most elegant banquet hall. Neither high humidity or inclement weather present a problem to the versatile Weather-All bar.

Use it inside, poolside, oceanside or beach. It will give years of durable, dependable service when properly maintained.

Because it's completely mobile on 5 inch diameter polyurethane tire casters, you can roll it to where the crowds (and profits) are, to save table service, labor and provide faster service to customers.

For even more efficient service, the matching Weather-All Ice Cart and Back Bar are perfect companions to FWE's functional indoor/outdoor bar.

- ◇ Indoor / outdoor usage
- ◇ Welded steel top and bottom frames
- ◇ Raised marine front edge retard spills
- ◇ Rugged polyurethane tire casters
- ◇ Stainless steel work surface and splash area with coved corners
- ◇ Stainless steel ice sink with shut-off drain valve
- ◇ Removable bottle speed rack
- ◇ Handy underbar server with 4 bowls
- ◇ Towel ring
- ◇ Large storage areas
- ◇ Two year limited warranty

PROJECT:

MODEL:

QUANTITY:

ITEM NO:

SPECIFICATIONS:

WEATHER-ALL "SCB SERIES" BARS available with matching Back-Up Bar and Ice Cart

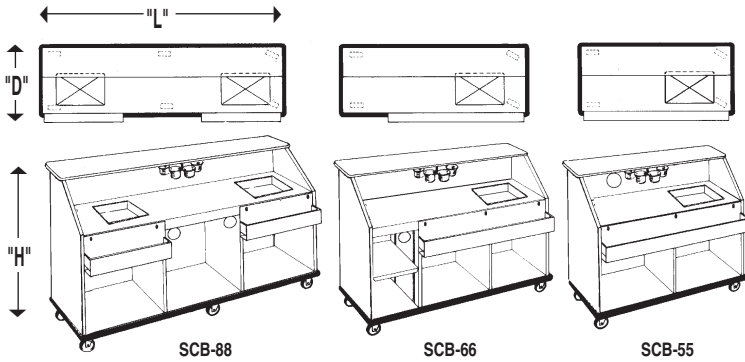

SCB-88

SCB-66

SCB-55

MODEL NUMBER	OVERALL EXTERIOR DIMENSIONS IN. (mm)			WORKING AREA HEIGHT	BULK STORAGE AREA	BOTTLE RACK CAPACITY [A]	CASTER SIZE	SHIP WT. LBS. (KG)
	HIGH "H"	DEEP "D" [A]	LONG "L"					
SCB-5 (Without Bumper)	45.5" (1156)	26.5" (673)	60" (1524)	35.5" (902)	27" H x 23" D	12 qts	5"	480 (218)
SCB-55 with Full Bumper	45.5" (1156)	28.5" (724)	62" (1575)	35.5" (902)	27" H x 23" D	12 qts	5"	500 (227)
SCB-6 (Without Bumper)	45.5" (1156)	26.5" (673)	72" (1829)	35.5" (902)	27" H x 23" D	12 qts	5"	555 (252)
SCB-66 with Full Bumper	45.5" (1156)	28.5" (724)	74" (1880)	35.5" (902)	27" H x 23" D	12 qts	5"	575 (261)
SCB-8 (Without Bumper)	45.5" (1156)	26.5" (673)	96" (2438)	35.5" (902)	27" H x 23" D	16 qts	5"	600 (272)
SCB-88 with Full Bumper	45.5" (1156)	28.5" (724)	98" (2489)	35.5" (902)	27" H x 23" D	16 qts	5"	620 (281)

[A] Removable bottle speed rack extends 3-1/2" beyond depth dimension.

WEATHER-ALL BARS:

CONSTRUCTION. Heliarc welded, single unit construction shall consist of welded stainless steel base frame of heavy gauge 1" square stainless steel tubing with extra 10-gauge stainless steel caster corner plate reinforcements.

BODY / TOP MATERIALS. Shall be stainless steel, heliarc welded; ground and polished. Interior work surface shall be constructed of stainless steel, with easy to clean coved corners. Front edge of work surface shall have raised marine nosing to retard spills.

CASTERS. Polyurethane tire casters in a configuration of two (2) rigid, and two (2) swivel with brake. Casters shall have a reinforced yoke welded to 10-gauge castor mounting plate. The caster mounting plate shall be secured to a 10-gauge stainless steel reinforcing stress plate via welded in place stainless steel studs. The reinforcing stress plates shall be welded to the heavy gauge tubular frame of the unit. Eight (8) foot models are equipped with six (6) casters: four (4) rigid casters and two (2) swivel with brake.

BUMPERS. Full bumper models shall have solid 1-1/2" wide continuous wraparound aluminum channel, bolted to frame, with snap-in, non-marking replaceable vinyl cushion. Full perimeter bumper shall be continuous, for added protection, with corner cut-outs to facilitate cleaning.

STORAGE AREA. On six (6) foot models, the glass storage area shall include removable and adjustable stainless steel shelf. On all models, the bottom storage area shall be stainless steel lined.

ICE SINK. Sink shall be one-piece stainless steel with coved corners: 18-1/2" x 16" x 6-1/2" deep with shut-off drain valve. Sink shall be undercoated to retard condensation.

BAR ACCESSORIES. Standard equipment shall include 5" deep, heavy gauge stainless steel bottle speed rack (extends 3-1/2" beyond depth dimension of 31.5"); removable without tools. Revolving underbar server shall have four (4) removable bowls. Towel ring shall be provided.

Optional Accessories:

- Locking bottle speed rack
- Extra stainless steel shelves
- Locking doors for storage areas
- Stainless steel bar gutters
- Protective storage cover
- All swivel casters
- All swivel with brake casters
- Vertical corner guards

FWE Products are used by major companies world-wide. We can modify, design, or custom build equipment to fit your special requirements.



ICE STORAGE CART
SIC-222

Holds 200 lbs. of ice! Fully insulated. Flip-top stainless lid. Drain, push bar handle, and all swivel 5" casters. Welded steel frame.



BACK BAR
SPSC-44

Enclosed on 3-sides! Stores glasses and bar accessories. Convenient work/serve black top. Stainless steel interior shelves on 9.5", 11.5", and 14" spacings. Welded steel frame. 5" casters.

MODEL NUMBER	OVERALL EXTERIOR DIMENSIONS IN. (mm)			ICE TANK CAPACITY	CASTER SIZE	SHIP WT. LBS. (KG)
	HIGH "H"	DEEP "D"	LONG "L"			
SIC-200 (Without Bumper)	33.5" (1156)	24.5" (648)	24.5" (648)	200 lbs	5"	140 (64)
SIC-222 with Full Bumper	33.5" (1156)	26.5" (673)	26.5" (673)	200 lbs	5"	150 (68)

MODEL NUMBER	OVERALL EXTERIOR DIMENSIONS IN. (mm)			CASTER SIZE	SHIP WT. LBS. (KG)
	HIGH "H"	DEEP "D"	LONG "L"		
SPSC-4 (Without Bumper)	45.5" (1156)	26.5" (673)	48" (1219)	5"	480 (218)
SPSC-44 with Full Bumper	45.5" (1156)	28.5" (724)	50" (1270)	5"	500 (227)
SPSC-6 (Without Bumper)	45.5" (1156)	26.5" (673)	72" (1829)	5"	555 (252)
SPSC-66 with Full Bumper	45.5" (1156)	28.5" (724)	75" (1905)	5"	575 (261)
SPSC-8 (Without Bumper)	45.5" (1156)	26.5" (673)	96" (2438)	5"	600 (272)
SPSC-88 with Full Bumper	45.5" (1156)	28.5" (724)	98" (2489)	5"	620 (281)



Food Warming Equipment Company, Inc.

P.O. Box 1001
Crystal Lake, IL 60039 USA
800-222-4393; 815-459-7500
Fax: 815-459-7989

Manufacturing Facilities:
7900 S. Route 31
Crystal Lake, IL 60014 USA
www.FWE.com sales@fweco.net

FWE products may be covered under one or more of the following U.S. patents: 288,299;238,300;3,952,609;4,192,991.

All specifications subject to change without notice.
© 11C Food Warming Equipment Company, Inc.